



CAMBRIDGE
International Examinations

Cambridge
O Level

Example Candidate Responses (Standards Booklet)

Cambridge O Level
Mathematics (Syllabus D)
4024

Cambridge International Examinations retains the copyright on all its publications. Registered Centres are permitted to copy material from this booklet for their own internal use. However, we cannot give permission to Centres to photocopy any material that is acknowledged to a third party even for internal use within a Centre.

© Cambridge International Examinations October 2014

Contents

Introduction.....	2
Assessment at a glance.....	3
Paper 1	4
Paper 2	93

Introduction

The main aim of this booklet is to exemplify standards for those teaching Cambridge O Level Mathematics (Syllabus D) (4024), and to show how different levels of candidates' performance relate to the subject's curriculum and assessment objectives.

A range of candidate responses has been chosen as far as possible to exemplify grades A, C and E. Each response is accompanied by a brief commentary explaining the strengths and weaknesses of the answers.

In this booklet a grade is given to each question but in the examination each question paper (whole candidate script) is graded on the overall mark awarded, not on each question or part question. It is therefore possible that, on some questions that lower grade candidate example answers are awarded the same or similar marks to higher grade candidate example answers.

The following format for each paper has been adopted:

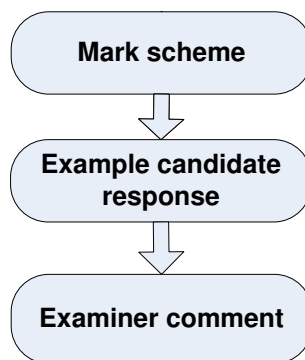

The mark scheme used by examiners for each question is followed by examples of candidate responses, each with an examiner comment on performance. Comments are given to indicate where and why marks were awarded, and how additional marks could have been obtained. In this way, it is possible to understand what candidates have done to gain their marks and what they still have to do to improve their grades.

Past papers, examiner reports and other teacher support materials are available on Teacher Support at <http://teachers.cie.org.uk>

Assessment at a glance

All candidates take two papers.

Each paper may contain questions on any part of the syllabus and questions will not necessarily be restricted to a single topic.

Paper 1

2 hours

Paper 1 has approximately 25 short answer questions.

Candidates should show all working in the spaces provided on the question paper. Omission of essential working will result in loss of marks.

No calculators are allowed for this paper.

80 marks weighted at 50% of the total

Paper 2

2½ hours

Paper 2 has structured questions across two sections.

Section A (52 marks): approximately six questions. Candidates should answer all questions.

Section B (48 marks): five questions. Candidates should answer four.

Electronic calculators may be used.

Candidates should show all working in the spaces provided on the question paper. Omission of essential working will result in loss of marks.

100 marks weighted at 50% of the total

Teachers are reminded that a full syllabus is available at www.cie.org.uk.

Paper 1

Question 1

Mark scheme

Question	Answers	Mark	Part Marks
1 (a)	14	1	
(b)	0.30e	1	

Example candidate response – grade A

1 (a) Evaluate $12 + 8 \div (9 - 5)$.

$$12 + 8 \div 4$$

$$12 + 2$$

Answer14..... [1]

(b) Evaluate $0.018 \div 0.06$.

$$\frac{0.018}{0.06} = \frac{1.8}{6} = 0.3$$

Answer0.3..... [1]

Examiner comment – grade A

(a) Each stage of working is clearly shown, from simplifying the bracket to the correct evaluation of the expression.

Mark awarded = 1 out of 1

(b) The problem is clearly set out as a division. The necessary changes have been made in the numerator and denominator so that the division can be carried out accurately.

Mark awarded = 1 out of 1

Total mark awarded = 2 out of 2

Example candidate response – grade C

- 1 (a) Evaluate
- $12 + 8 \div (9 - 5)$
- .

$$12 + 8 \div (4)$$

$$12 + 2 = 14$$

Answer 14 [1]

- (b) Evaluate
- $0.018 \div 0.06$
- .

$$\frac{0.018}{1000} \div \frac{0.06}{100} = \frac{18 \times 100}{1000 \cdot 6} = \frac{1800}{6000}$$

Answer 2 [1]

Examiner comment – grade C

- (a) The expression is evaluated correctly. Candidates often quote BODMAS to remind themselves of the correct order of working.

Mark awarded = 1 out of 1

- (b) Each decimal number is correctly rewritten as a fraction and the correct adjustment is made from division to multiplication. The large numbers in the final fraction have been cancelled incorrectly.

Mark awarded = 0 out of 1**Total mark awarded = 1 out of 2**

Example candidate response – grade E

- 1 (a) Evaluate
- $12 + 8 \div (9 - 5)$
- .

$$20 \div (9 - 5)$$

$$20 \div 4 = \frac{20}{4} = 5$$

Answer 5 [1]

- (b) Evaluate
- $0.018 \div 0.06$
- .

$$\frac{0.018}{0.06}$$

Answer 0.003 [1]

Examiner comment – grade E

- (a) The candidate works as though the given expression had been written in the form
- $(12 + 8)$
- . This was a common error. Sometimes candidates introduce brackets into expressions of this type and answer a question that has not been set.

Mark awarded = 0 out of 1

- (b) The candidate rewrites the given problem correctly. There is no further working on the paper.

Mark awarded = 0 out of 2**Total mark awarded = 0 out of 2**

Question 2

Mark scheme

2	(a)	9	1	
	(b)	-2.5	1	

Example candidate response – grade A

2 Tasnim records the temperature, in °C, at 6 a.m. every day for 10 days.

-6 -3 0 -2 -1 -7 -5 2 -1 -3

(a) Find the difference between the highest and the lowest temperatures.

$$2 - (-7) = 2 + 7 = 9^{\circ}\text{C}$$

(b) Find the median temperature.
 Answer 9 °C [1]
 $-7, -6, -5, -3, -3, -2, -1, -1, 0, 2$
 Median = $\left(\frac{10+1}{2}\right)^{\text{th}}$ value = 5.5th value = 5th and 6th value
 $\frac{(-4)(1) + (-3)(2) + 0 + (-2)(1) + (-1)(2) + (-7)(1) + (-5)(1) + 2(1)}{2} = \frac{-3 + (-2)}{2}$
 $= \frac{-3 - 2}{2} = \frac{-5}{2} = -2.5$
 $= \frac{-6 - 6 - 2 - 2 - 7 - 5 + 2}{10} = \frac{-26 + 2}{10} = \frac{-24}{10} = -2.4^{\circ}\text{C}$
 Answer ~~-2.4~~ -2.5 °C [1]

Examiner comment – grade A

(a) The candidate selects the highest and lowest temperatures in the list, forms the difference between them correctly, and evaluates it accurately.

Mark awarded = 1 out of 1

(b) After evaluating the mean, the candidate realises that it is the median temperature that is required. The data are reordered appropriately to find the median value. Sometimes the mean was the answer given in this question.

Mark awarded = 1 out of 1

Total mark awarded = 2 out of 2

Example candidate response – grade C

2 Tasnim records the temperature, in °C, at 6 a.m. every day for 10 days.

-6 -3 0 -2 -1 -7 -5 2 -1 -3

(a) Find the difference between the highest and the lowest temperatures.

$$2 - (-7)$$

$$= 2 + 7$$

$$= 9$$

Answer 9 °C [1]

(b) Find the median temperature.

$$\frac{-6 + 3 + 0 + 2 + 1 + 7 + 5 + 2 + 1 + 3}{10}$$

$$= \frac{30}{10}$$

$$= 3$$

Answer 3 °C [1]

Examiner comment – grade C

(a) The order of directed numbers is appreciated. Some candidates thought that the first value in the unordered list given in the question was the lowest temperature.

Mark awarded = 1 out of 1

(b) The candidate does not reorder the data. The magnitude of each temperature is taken and the mean of these values is found.

Mark awarded = 0 out of 1

Total mark awarded = 1 out of 2

Example candidate response – grade E

2 Tasnim records the temperature, in °C, at 6 a.m. every day for 10 days.

-6 -3 0 -2 -1 -7 -5 2 -1 -3

(a) Find the difference between the highest and the lowest temperatures.

~~20/23~~
~~9/8~~

Answer 9 - 5 °C [1]

(b) Find the median temperature.

median = $\frac{\text{total f}}{\text{total n}}$

$$= \frac{26}{10}$$

$$= 2.6$$

Answer 2.6 °C [1]

Examiner comment – grade E

- (a) The candidate selects the highest and lowest temperatures correctly. The answer given is their algebraic sum, not their difference. This was a common error.

Mark awarded = 0 out of 1

- (b) First of all, the working shows the correct process to find the mean of the temperatures. There is then a division by 2. So processes involved in the mean and the median have been mixed together. Since there are an even number of temperatures, the calculation of the median in this case involves finding the mean of the two middle values.

Mark awarded = 0 out of 1

Total mark awarded = 0 out of 2

Question 3

Mark scheme

3	(a)	Decimal between 0.75 and 0.875	1	
	(b)	Fraction between $\frac{3}{4}$ and $\frac{7}{8}$	1	E.g. $\frac{13}{16}$ or $\frac{4}{5}$

Example candidate response – grade A

$$\begin{array}{r} 0.83 \\ 6 \overline{) 5.00} \\ \underline{-48} \\ 20 \\ \underline{-18} \\ 2 \\ 5 \\ \underline{-6} \\ 1 \\ 5 \\ \underline{-6} \\ 1 \\ 5 \\ \underline{-6} \\ 1 \end{array}$$

It is given that $\frac{3}{4} < n < \frac{7}{8}$.

(a) Write down a decimal value of n that satisfies this inequality.

$\frac{3}{4} = 0.75$

$\frac{4}{6} = \frac{2}{3} = 0.6 \times$ $\frac{7}{8} = 0.87$

$\frac{4}{5} = 0.80$

Answer $0.75 < n < 0.87, n = 0.80$ [1]

(b) Write down a fractional value of n that satisfies this inequality.

Answer $\frac{4}{5}$ [1]

Examiner comment - grade A

- (a) This candidate converts the fractions showing the range for n into decimals. The decimal value of $\frac{7}{8}$ is truncated to 0.87 which does not affect the solution to the problem. An obvious decimal within the range is chosen for n .

Mark awarded = 1 out of 1

- (b) The candidate converts the correct decimal given in part (a) to a fraction.

Mark awarded = 1 out of 1

Total mark awarded = 2 out of 2

Example candidate response – grade C

3 It is given that $\frac{3}{4} < n < \frac{7}{8}$.

(a) Write down a decimal value of n that satisfies this inequality.

$$= 1.3 < n < 1.1$$

$$= 1.2$$

Answer 1.2 [1]

(b) Write down a fractional value of n that satisfies this inequality.

$$= \frac{4}{5}$$

Answer $\frac{4}{5}$ [1]

Examiner comment – grade C

(a) The decimal value of the reciprocal of each fraction is calculated.

Mark awarded = 0 out of 1

(b) The candidate is able to meet the demand given in the question to write down a suitable value.

Mark awarded = 1 out of 1

Total mark awarded = 1 out of 2

Example candidate response – grade E

3 It is given that $\frac{3}{4} < n < \frac{7}{8}$.

(a) Write down a decimal value of n that satisfies this inequality.

$$\begin{aligned} 0.75 < n < 0.8 \\ 0.8 - 0.75 \\ = 0.05 \end{aligned}$$

Answer 0.05 [1]

(b) Write down a fractional value of n that satisfies this inequality.

$$\begin{aligned} \frac{7}{8} - \frac{3}{4} \times 2 \\ \frac{7-6}{8} \\ = \frac{1}{8} \end{aligned}$$

Answer $\frac{1}{8}$ [1]

Examiner comment – grade E

- (a) The initial idea to convert the given fractions into decimals is a correct strategy. Although the values given are not completely accurate, they could have been used to find a suitable value of n . The next step indicates that this candidate is solving the inequality $\frac{3}{4} + n < \frac{7}{8}$.

Mark awarded = 0 out of 1

- (b) The working continues with the same misunderstanding.

Mark awarded = 0 out of 1

Total mark awarded = 0 out of 2

Question 4

Mark scheme

4	(a)	47	1	
	(b)	11 03	1	

Example candidate response – grade A

- 4 Here is part of a bus timetable.

Bus station	0956	1026	1056	1126	1156
City Hall	1003	1033	1103	1133	1203
Railway station	1017	1047	1117	1147	1217
Hospital	1028	1058	1128	1158	1228
Airport	1043	1113	1143	1213	1243

$$\begin{array}{r} 11\ 13 \\ -10\ 26 \\ \hline 0\ 47 \end{array}$$

$$\begin{array}{r} 12\ 43 \\ -0\ 456 \\ \hline 00\ 47 \end{array}$$

- (a) How long does the bus take to get from the bus station to the airport?

$$10\ 43 - 09\ 56 = 47\ \text{min}$$

Answer 47 minutes [1]

- (b) Chris has a flight from the airport at 1405. He must check in at the airport 2 hours before the flight. He will take a bus to the airport from the City Hall.

Write down the latest time that Chris can take a bus from the City Hall to be at the airport in time.

Time to get to airport = 1205
 ∴ Chris will take a bus at 1103

Answer 11 03 [1]

Examiner comment – grade A

(a) This solution shows appropriate working. A formal subtraction using relevant times is worked out correctly. This candidate checks that a different bus takes the same time.

Mark awarded = 1 out of 1

(b) Again, the thinking required is explained in the working.

Mark awarded = 1 out of 1

Total mark awarded = 2 out of 2

Example candidate response – grade C

4 Here is part of a bus timetable.

Bus station	09 56	10 26	10 56	11 26	11 56
City Hall	10 03	10 33	11 03	11 33	12 03
Railway station	10 17	10 47	11 17	11 47	12 17
Hospital	10 28	10 58	11 28	11 58	12 28
Airport	10 43	11 13	11 43	12 13	12 43

Handwritten calculations:
 $10:43 - 9:56 = 48$
 $12:03 - 10:56 = 47$

(a) How long does the bus take to get from the bus station to the airport?

departure - journey -

$0956 - 1043 = 48$

Answer 48 minutes [1]

(b) Chris has a flight from the airport at 1405. He must check in at the airport 2 hours before the flight. He will take a bus to the airport from the City Hall.

Write down the latest time that Chris can take a bus from the City Hall to be at the airport in time.

$1405 - 2 \text{ hrs} = 1205$

Answer 12.03 [1]

Examiner comment – grade C

(a) Appropriate times are selected. The subtraction takes into account that there are 60 minutes in an hour. The minutes column is incorrectly adjusted to 104 minutes.

Mark awarded = 0 out of 1

(b) This solution has related the time of 12 05 to the timetable, but doesn't take into account the time required to travel from City Hall to the airport.

Mark awarded = 0 out of 1

Total mark awarded = 0 out of 2

Example candidate response – grade E

4 Here is part of a bus timetable.

Bus station	09 56	10 26	10 56	11 26	11 56
City Hall	10 03	10 33	11 03	11 33	12 03
Railway station	10 17	10 47	11 17	11 47	12 17
Hospital	10 28	10 58	11 28	11 58	12 28
Airport	10 43	11 13	11 43	12 13	12 43

(a) How long does the bus take to get from the bus station to the airport?

$$\begin{array}{r} 12\ 43 \\ - 11\ 56 \\ \hline 00\ 87 \end{array}$$

Answer 87 minutes [1]

(b) Chris has a flight from the airport at 14 05.
He must check in at the airport 2 hours before the flight.
He will take a bus to the airport from the City Hall.

Write down the latest time that Chris can take a bus from the City Hall to be at the airport in time.

$$\begin{array}{r} 10\ 43 \\ - 10\ 03 \\ \hline 00\ 40 \end{array}$$

$$\begin{array}{r} 12\ 05 \\ - 00\ 40 \\ \hline 11\ 25 \end{array}$$

Answer 11.25 [1]

Examiner comment – grade E

(a) Appropriate times are selected. These are then treated as 4-digit numbers, so subtraction gives the answer 87.

Mark awarded = 0 out of 1

(b) Two correct pieces of information are established. The check-in time at the airport, and the length of time a bus takes to get to the airport from City Hall. These are used to calculate the time 11 25. Here, the candidate has not understood the significance of the latest time that a bus from City Hall will reach the airport in time. So instead of working back from 11 25 to get to 11 03, this candidate gives 11 25 as the answer even though there is no 11 25 bus on the timetable.

Mark awarded = 0 out of 1

Total mark awarded = 0 out of 2

Question 5

Mark scheme

5	(a)	8.52×10^{-5} final answer	1	
	(b)	5×10^6	1	

Example candidate response – grade A

5 (a) Express 0.0000852 in standard form.

$$8.52 \times 10^{-65}$$

Answer 8.52×10^{-5} [1]

(b) Calculate $(3 \times 10^5) \div (6 \times 10^{-2})$, giving your answer in standard form.

$$\begin{aligned} & \frac{3 \times 10^5}{6 \times 10^{-2}} \\ &= \frac{1}{2} \times 10^{5+2} \\ &= \frac{1}{2} \times 10^7 \\ &= 2 \times 10^{-6} \end{aligned}$$

Answer 2×10^{-6} [1]

Examiner comment – grade A

(a) The candidate has converted the given number correctly.

Mark awarded = 1 out of 1

(b) The calculation is correct as far as $\frac{1}{2} \times 10^7$. In continuing to work towards expressing this number in standard form, incorrect ideas concerning reciprocals and negative powers become apparent.

Mark awarded = 0 out of 1

Total mark awarded = 1 out of 2

Example candidate response – grade C

- 5 (a) Express 0.0000852 in standard form.

$$= 0.0000852$$

$$= 852 \times 10^{-5}$$

Answer 852×10^{-5} [1]

- (b) Calculate $(3 \times 10^5) \div (6 \times 10^{-2})$, giving your answer in standard form.

$$= \frac{(3 \times 10^5)}{(6 \times 10^{-2})} = 2 \times 10^3$$

Answer 2×10^3 [1]

Examiner comment – grade C

- (a) 10^{-5} is reached but 852 has not been adjusted.

Mark awarded = 0 out of 1

- (b) The initial calculation is set out correctly in fraction form. The final result shows some misunderstanding of relationships involving reciprocals and negative indices.

Mark awarded = 0 out of 0

Total mark awarded = 0 out of 2

Example candidate response – grade E

- 5 (a) Express 0.0000852 in standard form.

$$8.52 \times 10^{-6}$$

Answer 8.52×10^{-6} [1]

- (b) Calculate $(3 \times 10^5) \div (6 \times 10^{-2})$, giving your answer in standard form.

$$3 \times 50 \div 6 \times 0.20$$

$$\begin{array}{r} \times \begin{array}{r} 50 \\ 3 \\ \hline 150 \end{array} \\ \hline \end{array}$$

$$\frac{150}{100} \div \frac{6.02}{100} = 6.20$$

$$150 \sqrt{6.20}$$

Answer [1]

Examiner comment – grade E

(a) 8.52 is achieved but not to the required power of 10.

Mark awarded = 0 out of 1

(b) Here, both numbers are incorrectly converted to other forms.

Mark awarded = 0 out of 1

Total mark awarded = 0 out of 2

Question 6

Mark scheme

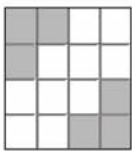
6 (a)	Rotational symmetry of order 3 0 lines of symmetry	1	Both correct
(b)	Pattern completed correctly	1	

Example candidate response – grade A

6 (a) Complete the description of the pattern below.

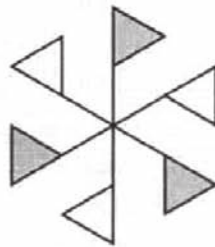

The pattern has rotational symmetry of order 3.....

and 0..... lines of symmetry.

[1]

(b) Shade in **two** more small squares in this shape to make a pattern with exactly 2 lines of symmetry.

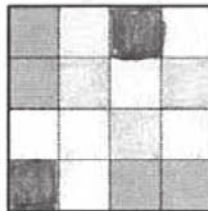

[1]

Examiner comment – grade A

(a) The description has been completed correctly.

Mark awarded = 1 out of 1

(b) The heavier shading seems to imply the candidate’s final answer. The grid shows evidence of working with one of the expected lines of symmetry. In some scripts, lines of symmetry were drawn on the grid to assist in building up a correct solution.

Mark awarded = 0 out of 1

Total mark awarded = 1 out of 2

Example candidate response – grade C

6 (a) Complete the description of the pattern below.

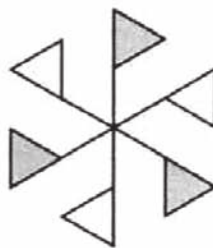

The pattern has rotational symmetry of order6.....

and9..... lines of symmetry.

[1]

(b) Shade in **two** more small squares in this shape to make a pattern with exactly 2 lines of symmetry.

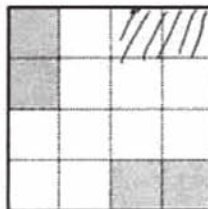

[1]

Examiner comment – grade C

(a) The number of lines of symmetry is correct. In describing the rotational symmetry, the shading given in the diagram in the question has not been taken into account.

Mark awarded = 0 out of 1

(b) The candidate appears to have thought that the two extra squares shaded in were to be regarded as a separate shape having two lines of symmetry, and to be independent of the rest of the diagram.

Mark awarded = 0 out of 1

Total mark awarded = 0 out of 2

Example candidate response – grade E

6 (a) Complete the description of the pattern below.

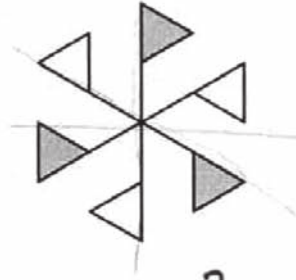

The pattern has rotational symmetry of order2.....
and3..... lines of symmetry.

[1]

(b) Shade in **two** more small squares in this shape to make a pattern with exactly 2 lines of symmetry.

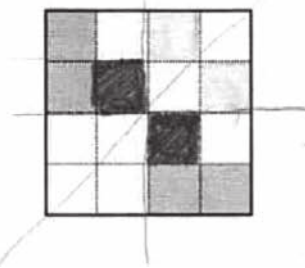

[1]

Examiner comment – grade E

(a) The two colours seem to have had some bearing on the thinking here.

Mark awarded = 0 out of 1

(b) The three flags of each colour have possibly influenced the thinking here.

Mark awarded = 0 out of 1

Total mark awarded = 0 out of 2

Question 7

Mark scheme

7	54	2	C1 for answer 36 Or B1 for $k = \frac{3}{200}$ oe or for $\frac{C}{24} = \frac{60^2}{40^2}$
---	----	---	--------------------------------------------------------------------------------------------------------------

Example candidate response – grade A

- 7 The cost of a mirror is directly proportional to the square of its width.
A mirror of width 40 cm costs \$24.

Work out the cost of a mirror of width 60 cm.

$c = \text{Cost}$
 $w = \text{width}$

$k = \frac{24}{1600}$
 $k = 0.015$
 $C \propto w^2$
 $C = kw^2$
 $24 = k(40)^2$
 $24 = k(1600)$

$C = 0.015 \times (60)^2$
 $C = 0.015 \times 3600$

$C = 54$

Answer \$..... 54 [2]

$\frac{36000 \times 0.015}{10}$
 $\frac{60}{20} = \frac{60}{60}$
 $\frac{3600 \times 0.015}{3600} = \frac{300}{1000}$
 $200 \sqrt{\frac{300}{1000}}$
 $\frac{24}{1600} = \frac{C}{3600}$
 $\frac{24}{1600} \times 3600 = C$
 $\frac{24 \times 36}{16} = C$
 $\frac{24 \times 9}{4} = C$
 $\frac{216}{4} = C$
 $54 = C$

Examiner comment – grade A

The candidate was able to express the problem in algebraic terms, and use the algebra to find the unknown quantity.

Mark awarded = 2 out of 2

Example candidate response – grade C

- 7 The cost of a mirror is directly proportional to the square of its width.
A mirror of width 40 cm costs \$24.

Work out the cost of a mirror of width 60 cm.

$$y = kx$$

$$24 = k \cdot 40$$

$$5 \times 40 = k \cdot 24$$

$$\frac{200}{24} = k \quad k = \frac{5}{3}$$

$$k = \frac{5}{3}$$

$$y = kx$$

$$60 = \frac{5}{3} x$$

$$\frac{60 \times 3}{5} = x$$

$$\frac{180}{5}$$

Answer \$.....36..... [2]

Examiner comment – grade C

This candidate has not taken account of the condition ‘the square of its width.’ Although seemingly in two minds as to how to deal with the situation algebraically, the outcome in terms of direct proportion is successful.

Mark awarded = 1 out of 2

Example candidate response – grade E

- 7 The cost of a mirror is directly proportional to the square of its width.
A mirror of width 40 cm costs \$24.

Work out the cost of a mirror of width 60 cm.

$$y \propto kx^2$$

$$24 = k(40)^2$$

$$24 = k \cdot 1600$$

$$k = \frac{24}{1600} = \frac{3}{200}$$

$$y = \frac{3}{200} x^2$$

$$y = \frac{3}{200} (60)^2$$

$$y = \frac{3}{200} \cdot 3600$$

$$y = \frac{10800}{200} = 54$$

$$y \propto kx^2$$

$$y = \frac{10}{3} x (60)^2$$

$$y = \frac{10}{3} x 120 \cdot 60$$

Answer \$.....600..... [2]

Examiner comment – grade E

Correct algebraic thinking is shown. The work involving indices is incorrect.

Mark awarded = 1 out of 2

Question 8

Mark scheme

8	(a)	Isosceles	1	
	(b)	128°	1	

Example candidate response – grade A

- 8 A and B are points on the circle, centre O .
 TA and TB are tangents to the circle.
 $\hat{BAT} = 64^\circ$.

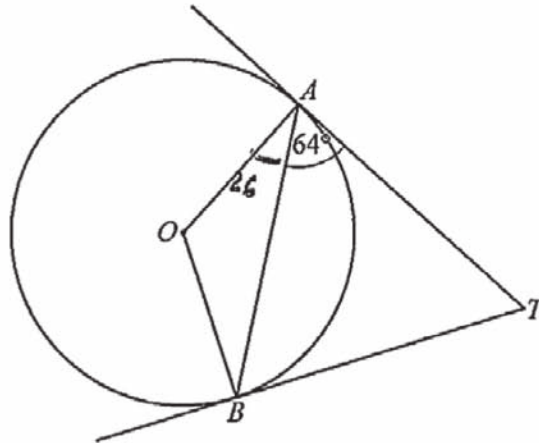

- (a) What special type of triangle is triangle ABT ?

Answer Isosceles [1]

- (b) Work out \hat{AOB} .

$$\begin{aligned} 90 - 64 \\ = 26 \\ 180 - 26 - 26 \\ = 128 \end{aligned}$$

Answer $\hat{AOB} =$ 128 [1]

Examiner comment – grade A

- (a) This is a convincing attempt to write isosceles. The candidate appreciates the situation without the need to embellish the diagram.

Mark awarded = 1 out of 1

- (b) The candidate uses the right angles at A and B effectively and gives an accurate expression for the required angle. Another written out stage in the subtraction could have been shown.

Mark awarded = 0 out of 1

Total mark awarded = 1 out of 2

Example candidate response – grade C

- 8 A and B are points on the circle, centre O :
 TA and TB are tangents to the circle.
 $\hat{BAT} = 64^\circ$.

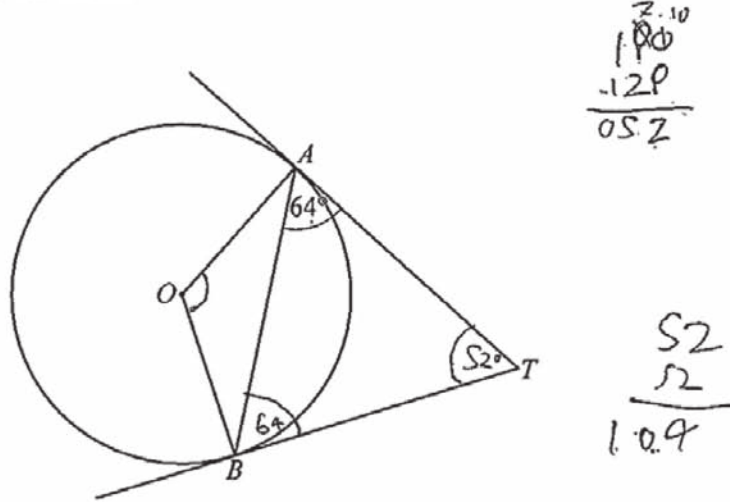

- (a) What special type of triangle is triangle ABT ?

Answer *equal* [1]

- (b) Work out \hat{AOB} .

Answer $\hat{AOB} =$ *104* [1]

Examiner comment – grade C

- (a) The candidate has used the appropriate symmetry property of a circle to obtain angle ABT . The candidate appears to have had ‘equilateral’ in mind rather than ‘isosceles’.

Mark awarded = 0 out of 1

- (b) There is a correct calculation to find \hat{ATB} . There is no reference to the right angles at A and B . The centre O seems to have prompted the idea of the angle at the centre of a circle and twice the angle at the circumference, but this idea is applied inappropriately here.

Mark awarded = 0 out of 1

Total mark awarded = 0 out of 2

Example candidate response– grade E

- 8 A and B are points on the circle, centre O .
 TA and TB are tangents to the circle.
 $\hat{B}AT = 64^\circ$.

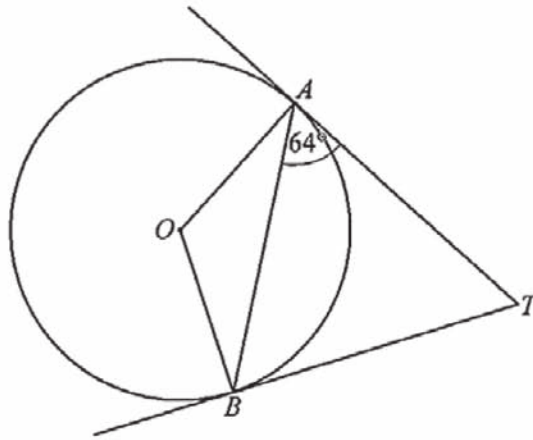

- (a) What special type of triangle is triangle ABT ?

Answer It is a 90° triangle [1]

- (b) Work out $\hat{A}OB$.

$$= 90 - 64$$

$$= 26^\circ$$

Answer $\hat{A}OB =$ 26° [1]

Examiner comment – grade E

- (a) There is a right angle in the diagram but it is not related to the given triangle. The answer given is not one of the descriptions referred to as special.

Mark awarded = 0 out of 1

- (b) The right angle appears again, and this could be the start of a correct solution. The relevance of the calculation shown to the problem being solved is not brought out.

Mark awarded = 0 out of 1

Total mark awarded = 0 out of 2

Question 9

Mark scheme

9	(a)	$\frac{25}{28}$ oe final answer	1	
	(b)	$3\frac{1}{3}$ final answer	2	B1 for $\frac{10}{3}$ oe or for $\frac{16}{3} \times \frac{5}{8}$

Example candidate response – grade A

9 (a) Evaluate $\frac{1}{7} + \frac{3}{4}$.

$$= \frac{4 + 21}{28}$$

$$= \frac{25}{28}$$

Answer $\frac{25}{28}$ [1]

(b) Evaluate $5\frac{1}{3} \div 1\frac{3}{5}$, giving your answer as a mixed number in its lowest terms.

$$\frac{16}{3} \div \frac{8}{5}$$

$$\frac{16}{3} \times \frac{5}{8}$$

$$= \frac{10}{3}$$

$$= 3\frac{1}{3}$$

Answer $3\frac{1}{3}$ [2]

Examiner comment – grade A

(a) The candidate applies a standard written method showing the two equivalent fractions as a single fraction.

Mark awarded = 1 out of 1

(b) The process of division is carried out correctly. The requirement to express the answer as a mixed number has been interpreted incorrectly.

Mark awarded = 1 out of 2

Total mark awarded = 2 out of 3

Example candidate response – grade C

9 (a) Evaluate $\frac{1}{7} + \frac{3}{4}$.

$$\frac{7}{7} + \frac{3}{4}$$

$$= \frac{4(1) + 7(3)}{28}$$

$$\frac{4 + 21}{28} = \frac{25}{28}$$

Answer $\frac{25}{28}$ [1]

(b) Evaluate $5\frac{1}{3} \div 1\frac{3}{5}$, giving your answer as a mixed number in its lowest terms.

$$\frac{16}{3} \div \frac{8}{5}$$

$$\frac{16}{3} \times \frac{5}{8}$$

$$16 \times 5 = 8 \times 3$$

$$128 = 15$$

$$\frac{128}{15} =$$

$$\frac{28}{15}$$

Answer $\frac{28}{15}$ [2]

Examiner comment – grade C

(a) A standard written method for the addition of fractions is carefully worked.

Mark awarded = 1 out of 1

(b) The process of division is correctly handled with the appropriate change to multiplication. At this point, the four numbers involved are treated as though in an equation where cross multiplication would be appropriate.

Mark awarded = 1 out of 2**Total mark awarded = 2 out of 3**

Example candidate response – grade E

9 (a) Evaluate $\frac{1}{7} + \frac{3}{4}$.

$$\frac{1 \times 4 + 3 \times 7}{28}$$

$$\frac{4 + 21}{28} = \frac{25}{28}$$

Answer $\frac{25}{28}$ [1]

(b) Evaluate $5\frac{1}{3} \div 1\frac{3}{5}$, giving your answer as a mixed number in its lowest terms.

$$\frac{16}{3} \div \frac{8}{5}$$

$$2\frac{16}{3} \times \frac{5}{8}$$

$$\frac{10}{3}$$

Answer $10/3$ [2]

Examiner comment – grade E

(a) Secure technique is shown with this operation.

Mark awarded = 1 out of 1

(b) The lowest terms condition is met at the earliest opportunity. However, the candidate has not taken account of the demand to express the answer as a mixed number.

Mark awarded = 1 out of 2

Total mark awarded = 2 out of 3

Question 10

Mark scheme

10 (a)	406 000 000 oe	1	
(b)	5	2	B1 for two of 40, 10 and 0.8 seen

Example candidate response – grade A

10 (a) Write 405917.628 correct to three significant figures.

$$405,917.628$$

$$\therefore 406 \cdot 0$$

Answer 406 000 000 [1]

(b) By writing each number correct to one significant figure, estimate the value of

$$\frac{41.3}{9.79 \times 0.765}$$

$\begin{aligned} &= 40 \\ &4 \times 10 \end{aligned}$
 $\begin{aligned} &\textcircled{1} 41.3 \\ &= 40 \\ &\textcircled{2} 9.79 \\ &= 10 \\ &\textcircled{3} 0.765 \\ &= 0.8 \end{aligned}$
 $\therefore = \frac{400}{10 \times 0.8}$
 $= 40$

Answer 40 [2]

Examiner comment – grade A

(a) The candidate indicates the change that is required in order to express the number correct to three significant figures. The correction is completed in the answer space.

Mark awarded = 1 out of 1

(b) The candidate has read the question carefully and writes each of the three numbers correct to one significant figure. The final calculation is incomplete. The 0.8 has not been taken into account.

Mark awarded = 1 out of 2

Total mark awarded = 2 out of 3

Example candidate response – grade C

10 (a) Write 405917628 correct to three significant figures.

Answer4060..... [1]

(b) By writing each number correct to one significant figure, estimate the value of

$$\frac{41.3}{9.79 \times 0.765}$$

$$\frac{40}{9.8 \times 0.8} \Rightarrow \frac{40^5}{8}$$

Answer $\frac{5}{1}$ [2]

Examiner comment – grade C

(a) The decimal point indicates that the candidate had in mind a three digit number as the correct form of the final answer.

Mark awarded = 0 out of 1

(b) The instructions given in the question are carried out. The subsequent arithmetic is accurate. Most candidates completed the calculation with the answer 5, rather than $\frac{5}{1}$.

Mark awarded = 2 out of 2

Total mark awarded = 2 out of 3

Example candidate response – grade E

10 (a) Write 405917628 correct to three significant figures.

4000

Answer4000..... [1]

(b) By writing each number correct to one significant figure, estimate the value of

$$\frac{41.3}{9.79 \times 0.765}$$

,

$$\frac{41}{10 \times 0.8}$$

$$\frac{41}{8}$$

Answer5..... [2]

Examiner comment – grade E

(a) It is not clear what this candidate understands by the description ‘three significant figures’.

Mark awarded = 0 out of 1

(b) This candidate converts only two of the numbers into the required form, arriving at 5 by an incorrect route.

Mark awarded = 1 out of 2

Total mark awarded = 1 out of 3

Question 11

Mark scheme

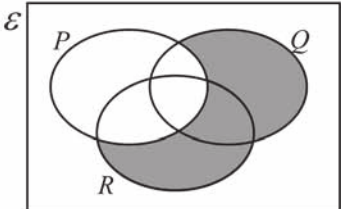
<p>11 (a)</p>		<p>1</p>	
<p>(b)</p>	<p>12</p>	<p>2</p>	<p>B1 for 8 seen</p>

Example candidate response – grade A

11 (a) On the Venn diagram, shade the set $P' \cap (Q \cup R)$.

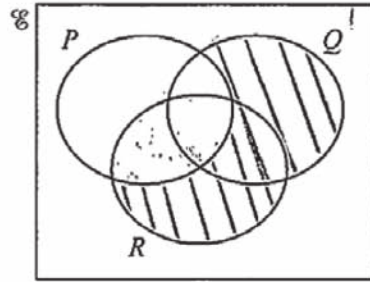

[1]

(b) A group of 40 children are asked what pets they own. Of these children, 13 own a cat, 5 own both a cat and a dog and 15 own neither a cat nor a dog.

Using a Venn diagram, or otherwise, find the number of children who own a dog, but not a cat.

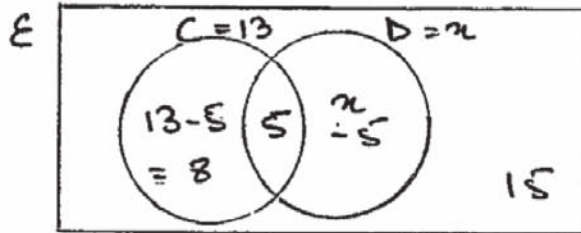

$$8 + 5 + x - 5 + 15 = 40$$

$$x + 23 = 40$$

$$x = 40 - 23$$

$$x = 17$$

17 people own a dog but not a cat

Answer 17 children [2]

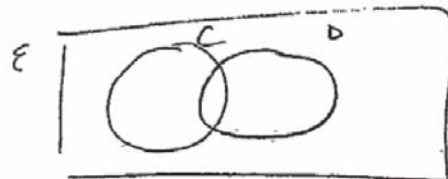

$$\begin{array}{r} 340 \\ - 23 \\ \hline 117 \end{array}$$

Examiner comment – grade A

(a) The required set is clearly shaded.

Mark awarded = 1 out of 1

(b) The candidate draws a clearly labelled Venn diagram. The entries are all correct, leading to an accurate equation. The candidate solves this equation, but at this point forgets that x is the number of children who own a dog. The adjustment to $(x - 5)$ is not made.

Mark awarded = 1 out of 2

Total mark awarded = 2 out of 3

Example candidate response – grade C

11 (a) On the Venn diagram, shade the set $P' \cap (Q \cup R)$.

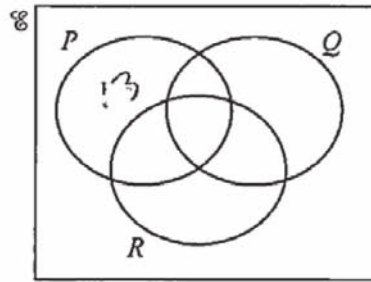

[1]

(b) A group of 40 children are asked what pets they own. Of these children, 13 own a cat, 5 own both a cat and a dog and 15 own neither a cat nor a dog.

Using a Venn diagram, or otherwise, find the number of children who own a dog, but not a cat.

$$\begin{array}{r} 3401 \\ -28 \\ \hline 12 \end{array}$$

$$40 = 13 + 5 + x = 15$$

$$40 = 18 + x - 15$$

$$40 = 3 + x$$

$$\begin{array}{r} 13 \\ 13 \\ \hline 28 \end{array}$$

Answer 12 [2]

Examiner comment – grade C

(a) The 13 here in the diagram given in the question is connected with part (b). There is no response to part (a).

Mark awarded = 0 out of 1

(b) Apart from the 13 noticed in the diagram in the question, the candidate does not use a Venn diagram here. The initial algebraic response leads to an impossible answer and is abandoned. A purely arithmetic approach is then used. The 28 and the subsequent subtraction of this from 40 are clear deductions from the data given in the question.

Mark awarded = 2 out of 2

Total mark awarded = 2 out of 3

Example candidate response – grade E

11 (a) On the Venn diagram, shade the set $P' \cap (Q \cup R)$.

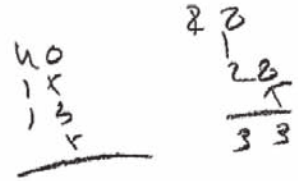
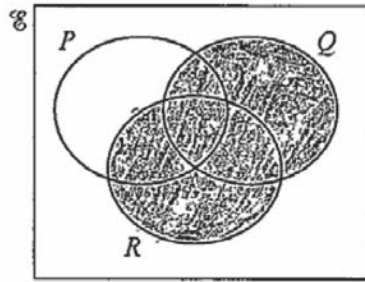

[1]

(b) A group of 40 children are asked what pets they own. Of these children, 13 own a cat, 5 own both a cat and a dog and 15 own neither a cat nor a dog.

7

Using a Venn diagram, or otherwise, find the number of children who own a dog, but not a cat.

$E \{ 1, \dots, 40 \}$
 cat $\{ 1, 2, 3, 4, 5, 6, 7, 8, 9, 10, 11, 12, 13 \}$
 cat and dog $\{ 1, 2, 3, 4, 5 \}$
 $= 15 + 13 + 5 = 33$
 $40 - 33$
 7

Answer 7 children [2]

Examiner comment – grade E

(a) The complement of P has not been taken into account here. A common error consisted of too much shading, often with the extra bit being the common part of all three sets.

Mark awarded = 0 out of 1

(b) This was a common wrong answer, more often seen in association with a Venn diagram. The method of working shown here is unusual. In effect, the five children who own both a cat and a dog have not been separated from the 13 who own a cat. The mark available for a correct use of eight is thus not earned either.

Mark awarded = 0 out of 2

Total mark awarded = 0 out of 3

Question 12

Mark scheme

12 (a)	$\begin{pmatrix} 172 \\ 206 \end{pmatrix}$ oe	2	B1 for one value correct
(b)	Amount taken on Monday and Tuesday	1	

Example candidate response – grade A

12 A café sells hot drinks.

On Monday it sells 80 teas, 60 coffees and 40 hot chocolates.

On Tuesday it sells 70 teas, 90 coffees and 50 hot chocolates.

A cup of tea costs \$0.80, a cup of coffee costs \$1 and a cup of hot chocolate costs \$1.20.

This information can be represented by the matrices **M** and **N** below.

$$M = \begin{pmatrix} 80 & 60 & 40 \\ 70 & 90 & 50 \end{pmatrix} \quad N = \begin{pmatrix} 0.8 \\ 1 \\ 1.2 \end{pmatrix}$$

(a) Work out **MN**.

$$\begin{pmatrix} 80 & 60 & 40 \\ 70 & 90 & 50 \end{pmatrix} \begin{pmatrix} 0.8 \\ 1 \\ 1.2 \end{pmatrix}$$

$$\begin{pmatrix} (80 \times 0.8) + (60 \times 1) + (40 \times 1.2) \\ (70 \times 0.8) + (90 \times 1) + (50 \times 1.2) \end{pmatrix}$$

$$\begin{pmatrix} 100 + 60 + 48 \\ 56 + 90 + 60 \end{pmatrix}$$

$$\begin{pmatrix} 208 \\ 206 \end{pmatrix}$$

Answer

$$\begin{pmatrix} 208 \\ 206 \end{pmatrix}$$

[2]

(b) Explain what the numbers in your answer represent.

Answer The total amount of money made on Monday (208) and Tuesday (206).

[1]

Examiner comment – grade A

- (a) The working shows that the required matrix multiplication is clearly understood. One incorrect product, $80 \times 0.8 = 100$, leads to an incorrect entry in the answer.

Mark awarded = 1 out of 2

- (b) The explanation makes reference to the amount of money taken by the café on each day.

Mark awarded = 1 out of 1

Total mark awarded = 2 out of 3

Example candidate response – grade C

12 A café sells hot drinks.

On Monday it sells 80 teas, 60 coffees and 40 hot chocolates.

On Tuesday it sells 70 teas, 90 coffees and 50 hot chocolates.

A cup of tea costs \$0.80, a cup of coffee costs \$1 and a cup of hot chocolate costs \$1.20.

This information can be represented by the matrices **M** and **N** below.

$$M = \begin{pmatrix} 80 & 60 & 40 \\ 70 & 90 & 50 \end{pmatrix} \quad N = \begin{pmatrix} 0.8 \\ 1 \\ 1.2 \end{pmatrix}$$

(a) Work out **MN**.

$$\begin{bmatrix} 80 \times 0.8 + 60 \times 1 + 40 \times 1.2 \\ 70 \times 0.8 + 90 \times 1 + 50 \times 1.2 \end{bmatrix}$$

$$\begin{bmatrix} 64 + 60 + 48 \\ 56 + 90 + 60 \end{bmatrix}$$

$$\begin{bmatrix} 174 \\ 206 \end{bmatrix}$$

Answer $\begin{bmatrix} 174 \\ 206 \end{bmatrix}$ [2]

(b) Explain what the numbers in your answer represent.

Answer they give us the total cost. [1]

Examiner comment – grade C

- (a) The multiplication required is understood. The six products are accurately computed. One row is incorrectly totalled.

Mark awarded = 1 out of 2

- (b) The idea of cost is correct, but there is no indication that the data refers to each day.

Mark awarded = 0 out of 1

Total mark awarded = 1 out of 3

Example candidate response – grade E

- 12 A café sells hot drinks.

On Monday it sells 80 teas, 60 coffees and 40 hot chocolates.

On Tuesday it sells 70 teas, 90 coffees and 50 hot chocolates.

A cup of tea costs \$0.80, a cup of coffee costs \$1 and a cup of hot chocolate costs \$1.20.

This information can be represented by the matrices **M** and **N** below.

$$M = \begin{pmatrix} 80 & 60 & 40 \\ 70 & 90 & 50 \end{pmatrix} \quad N = \begin{pmatrix} 0.8 \\ 1 \\ 1.2 \end{pmatrix}$$

- (a) Work out **MN**.

$$\begin{pmatrix} 80 & 60 & 40 \\ 70 & 90 & 50 \end{pmatrix} \begin{pmatrix} 0.8 \\ 1 \\ 1.2 \end{pmatrix}$$

$$\begin{pmatrix} 80 \times 0.8 & 60 \times 1 & 40 \times 1.2 \\ 70 \times 0.8 & 90 \times 1 & 50 \times 1.2 \end{pmatrix}$$

$$\begin{pmatrix} 64 & 60 & 48 \\ 56 & 90 & 60 \end{pmatrix}$$

Answer $\begin{pmatrix} 64 & 60 & 48 \\ 56 & 90 & 60 \end{pmatrix}$ [2]

- (b) Explain what the numbers in your answer represent.

Answer ...it presents that the teas were more sold on Monday than Tuesday and coffee on Tuesday were more sell and hot chocolate too. It is the cost. [1]

Examiner comment – grade E

- (a) Some correct ideas of matrix multiplication are apparent. The addition expected in each row is indicated then crossed out, leaving a matrix of the wrong shape. Some of the arithmetic is incorrect.

Mark awarded = 0 out of 2

- (b) Explanations were valid only if they followed a matrix of the correct shape.

Mark awarded = 0 out of 1

Total mark awarded = 0 out of 3

Question 13

Mark scheme

13 (a)	17	1	
(b)	$\frac{2-x}{3}$ oe	2	<p>C1 for $\frac{x-2}{3}$ oe</p> <p>B1 for $\frac{2-y}{3}$</p> <p>Or M1 for $x = 2 - 3y$ soi</p>

Example candidate response – grade A

13 $f(x) = 2 - 3x$

Find

(a) $f(-5)$,

$$\begin{aligned}
 f(-5) &= 2 - 3(-5) \\
 &= 2 + 15 \\
 &= 17
 \end{aligned}$$

Answer $f(-5) = \dots\dots\dots 17 \dots\dots\dots$ [1]

(b) $f^{-1}(x)$.

$$\begin{aligned}
 y &= 2 - 3x \\
 y - 2 &= -3x \\
 \frac{y-2}{-3} &= x \\
 f^{-1}(x) &= \frac{x-2}{-3}
 \end{aligned}$$

Answer $f^{-1}(x) = \dots\dots\dots \frac{x-2}{-3} \dots\dots\dots$ [2]

Examiner comment – grade A

(a) The working shows the accurate substitution and subsequent evaluation.

Mark awarded = 1 out of 1

(b) A good start is made by introducing y into the equation. The strategy adopted, solving the equation for x in terms of y , is correct. A sign error is made, possibly because two steps are attempted at the same time. Interchanging x and y at the end rounds the method off.

Mark awarded = 1 out of 2

Total mark awarded = 2 out of 3

Example candidate response – grade C

13 $f(x) = 2 - 3x$

Find

(a) $f(-5)$,

$$\begin{aligned} \Rightarrow f(-5) &\Rightarrow \\ f_x &= 2 - 3(-5) \\ &= 2 - 15 \end{aligned}$$

Answer $f(-5) = \dots\dots\dots -13 \dots\dots\dots$ [1]

(b) $f^{-1}(x)$.

$$\begin{aligned} f^{-1} &= 2 - 3x \\ y &= 2 - 3x \\ 3x &= 2 - y \\ x &= \frac{2 - y}{3} \\ \text{now replace } y &\text{ with } x. \\ &= \frac{2 - x}{3} \end{aligned}$$

Answer $f^{-1}(x) = \dots\dots\dots \frac{2-x}{3} \dots\dots\dots$ [2]

Examiner comment – grade C

(a) The substitution is correct. The product of two negative integers should be positive.

Mark awarded = 0 out of 1

(b) This work is clearly set out and fully explained. Any problems with negative numbers are avoided by transposing the expression and solving for x rather than $-x$.

Mark awarded = 2 out of 2

Total mark awarded = 2 out of 3

Example candidate response – grade E

13 $f(x) = 2 - 3x$

Find

(a) $f(-5)$,

$$\begin{aligned} 2 - 3(-5) \\ 2 - (-15) \\ 17 \end{aligned}$$

Answer $f(-5) = \dots\dots\dots 17 \dots\dots\dots$ [1]

(b) $f^{-1}(x)$.

$$\begin{aligned} y &= 2 - 3x \\ 2y &= 3x \end{aligned}$$

Answer $f^{-1}(x) = \dots\dots\dots = \frac{3x}{2} \dots\dots\dots$ [2]

Examiner comment – grade E

- (a) This solution shows the correct substitution and accurate evaluation of the product of two negative numbers.

Mark awarded = 1 out of 1

- (b) A correct start. There is a clear indication that this equation must be rearranged. The rearrangement, however, is incorrect. There is no final attempt to interchange x and y .

Mark awarded = 0 out of 2

Total mark awarded = 1 out of 3

Question 14

Mark scheme

14 (a)	35.5	1	
(b)	118	2	B1 for use of 34.5 and 24.5

Example candidate response – grade A

- 14 A rectangular garden has length 35 metres and width 25 metres. These distances are measured correct to the nearest metre.

- (a) Write down the upper bound of the length of the garden.

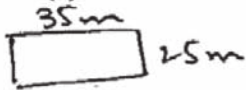

$$\begin{aligned} \text{length} &= 35\text{m} \\ 35 + 0.5 \end{aligned}$$

Answer 35.5 m m [1]

- (b) Work out the lower bound of the perimeter of the garden.

$$\begin{aligned} \text{lower bound} \\ \text{length} &= 34.5 \\ \text{width} &= 24.5 \end{aligned}$$

$$\begin{aligned} 34.5 + 34.5 + 24.5 + 24.5 \\ 69.0 + 49.0 \\ = 118\text{ m} \end{aligned}$$

$$\begin{array}{r} 34.5 \\ \underline{\quad 2} \\ 69.0 \\ \quad 16.9 \\ \quad \underline{4.9} \\ 118 \end{array} \quad \begin{array}{r} 34.5 \\ \underline{\quad 2} \\ 69.0 \\ \quad 16.9 \\ \quad \underline{4.9} \\ 118 \end{array}$$

Answer 118 m [2]

Examiner comment – grade A

- (a) The candidate shows clearly how the relevant upper bound is obtained.

Mark awarded = 1 out of 1

- (b) Both ideas, lower bound and perimeter, are clearly shown in the working.

Mark awarded = 2 out of 2

Total mark awarded = 3 out of 3

Example candidate response – grade C

- 14 A rectangular garden has length 35 metres and width 25 metres. These distances are measured correct to the nearest metre.

$$\begin{array}{r} 0.5 \\ 35 \\ \hline 35.5 \end{array}$$

- (a) Write down the upper bound of the length of the garden. 1/

$$35 \pm \frac{1}{2}$$

$$35 + 0.5 = 35.5 \approx 36$$

Answer 35.5 m [1]

- (b) Work out the lower bound of the perimeter of the garden.

$$35 - 0.5 = 34.5$$

$$25 - 0.5 = 24.5$$

$$L \times w =$$

$$34.5 \times 24.5$$

$$\begin{array}{r} 34.5 \\ 24.5 \\ \hline 1380 \\ 690 \\ \hline 835.25 \end{array}$$

Answer 835.25 m [2]

Examiner comment – grade C

- (a) The first step takes the appropriate quantity and indicates both upper and lower bounds. The correct one is chosen for the final answer.

Mark awarded = 1 out of 1

- (b) The correct lower bounds are chosen as required in this part. The answer given is the lower bound of the area.

Mark awarded = 1 out of 2

Total mark awarded = 2 out of 3

Example candidate response – grade E

- 14 A rectangular garden has length 35 metres and width 25 metres. These distances are measured correct to the nearest metre.

(a) Write down the upper bound of the length of the garden.

$$\begin{array}{l} \text{upper} \\ \text{bound} \end{array} \quad \begin{array}{l} 35 + 0.5 \\ = 35.5 \end{array}$$

Answer 35.5 m [1]

(b) Work out the lower bound of the perimeter of the garden.

$$\begin{array}{l} \cancel{l \times b} \\ = \cancel{35 \times 25} \\ 875 \\ \quad 35 + 25 \\ = 60 \\ = 60 - 0.5 \\ = 55.5 \end{array}$$



Answer 55.5 m [2]

Examiner comment – grade E

(a) The upper bound is correct.

Mark awarded = 1 out of 1

(b) A value for the semi-perimeter is calculated first, and then adjusted. This is an incorrect approach.

Mark awarded = 0 out of 2

Total mark awarded = 1 out of 3

Question 15

Mark scheme

15 (a)	0.5	1	
(b)	$x \geq 1$ $y \geq 0.5x + 1$ oe	2	FT their gradient in $y \geq mx + 1$ B1 for one correct Or B1 for both $x = 1$ and $y = 0.5x + 1$ soi

Example candidate response – grade A

15

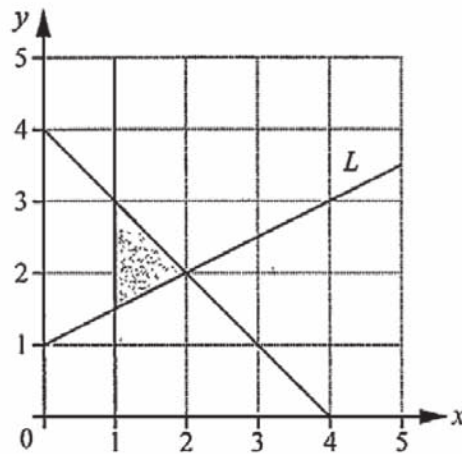

(a) Find the gradient of the line L. $m = \frac{3-2}{4-2} = \frac{1}{2}$

$(2, 2) (4, 3)$

$m = \frac{y_2 - y_1}{x_2 - x_1}$

Answer $\frac{1}{2}$ [1]

(b) The shaded region on the diagram is defined by three inequalities. One of these is $x + y \leq 4$

Write down the other two inequalities.

$x \geq 1$

$y - 2 = \frac{1}{2}(x - 2)$

$2y - 2 = x - 2$

$2y = x$

$y \geq \frac{x}{2}$

Answer $x \geq 1$ [2]

..... $y \geq \frac{x}{2}$

Examiner comment – grade A

- (a) The candidate obtains the coordinates of two points on the line by reading the grid carefully. The correct gradient is found.

Mark awarded = 1 out of 1

- (b) The candidate finds one of the inequalities readily. There is an attempt to form the equation of the line L to find the other inequality. The candidate is looking to relate $y - 2$ and $x - 2$ to the gradient $\frac{1}{2}$. Setting up the equation in the form $\frac{y-2}{x-2} = \frac{1}{2}$ may have helped to maintain accuracy in the resulting algebra.

Mark awarded = 1 out of 2

Total mark awarded = 2 out of 3

Example candidate response – grade C

15

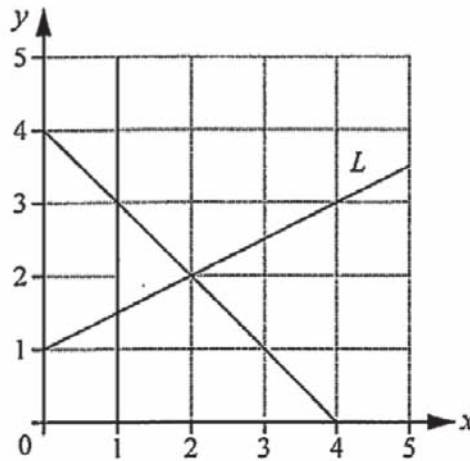

- (a) Find the gradient of the line L .

$(4, 3) \quad (0, 1)$

$$\frac{3-1}{4-0} = \frac{2}{4} = \frac{1}{2}$$

Answer $\frac{1}{2}$ 0.5 [1]

- (b) The shaded region on the diagram is defined by three inequalities.

One of these is $x + y \leq 4$.

Write down the other two inequalities.

Answer $x = 0$
 $x + y < 4$ [2]

Examiner comment – grade C

(a) This candidate forms the differences in y and x so that both are negative. The division is correctly resolved.

Mark awarded = 1 out of 1

(b) A correct equation is stated but the related inequality is not given. There is no working given to show why $x + y \leq 0.5$, or possibly 4.5, is given as a possible answer.

Mark awarded = 0 out of 2

Total mark awarded = 1 out of 3

Example candidate response – grade E

15.

$x/4$

less

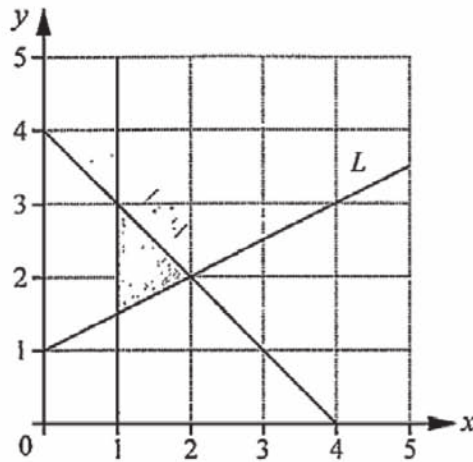

(a) Find the gradient of the line L .

$$\frac{x_2 - x_1}{y_2 - y_1} \quad x + 1$$

Answer [1]

(b) The shaded region on the diagram is defined by three inequalities. One of these is $x + y \leq 4$.

Write down the other two inequalities.

Answer $x = 1$

$y \leq 2$ [2]

Examiner comment – grade E

- (a) The general formula for a gradient using coordinates shows the difference in x divided by the difference in y . No values of x and y are substituted.

Mark awarded = 0 out of 1

- (b) The equation $x = 1$ is seen to be relevant, but the associated inequality is not given. $y < 2$ is not relevant to the given region.

Mark awarded = 0 out of 2

Total mark awarded = 1 out of 3

Question 16

Mark scheme

16 (a)	40	1	
(b)	56.25	1	
(c) (i)	225	1	
(ii)	400	1	

Example candidate response – grade A

- 16 (a) Dwayne buys a camera for \$90.
He sells the camera for \$126.

Calculate his percentage profit.

$$126 - 90 = 36$$

$$\frac{36}{126} \times 100 = \frac{3600}{126} = \frac{300}{7} = 42.8\%$$

Handwritten calculations for part (a):

- Subtraction: $126 - 90 = 36$
- Percentage calculation: $\frac{36}{126} \times 100 = 42.8\%$
- Final answer: $42.8\% \approx 43\%$

Answer 42.8% \approx 43% [1]

- (b) The price of a computer was \$375.
In a sale, the price was reduced by 15%.

Calculate the reduction in the price of the computer.

$$\begin{matrix} \$375 \\ \times \\ \hline \end{matrix}$$

$$\begin{matrix} 100\% \\ 85\% \\ \hline \end{matrix}$$

$$100x = 31875 \\ x = \frac{31875}{100} = 318.75$$

Handwritten calculations for part (b):

- Subtraction: $375 - 56.25 = 318.75$
- Percentage calculation: $100\% - 15\% = 85\%$
- Final answer: 318.75

Answer \$ 318.75 [1]

- (c) The exchange rate between euros and dollars is €1 = \$1.25.

- (i) Convert €180 to dollars.

$$\begin{matrix} \text{€} 1 & \$ 1.25 \\ 180 & \times \\ \hline \end{matrix}$$

$$x = 180 \times 1.25 = \$225$$

Handwritten calculations for part (c)(i):

- Substitution: $180 \times 1.25 = 225$
- Final answer: 225

Answer \$ 225 [1]

- (ii) Convert \$500 to euros.

$$\begin{matrix} \text{€} 1 & \$ 1.25 \\ \times & \$ 500 \\ \hline \end{matrix}$$

$$1.25x = 500 \\ x = \frac{500}{1.25} = 400$$

Handwritten calculations for part (c)(ii):

- Division: $500 \div 1.25 = 400$
- Final answer: 400

Answer € 400 [1]

Examiner comment – grade A

- (a) The actual profit is correct. The percentage profit needs to be evaluated with reference to the cost price, not the selling price.

Mark awarded = 0 out of 1

- (b) Tackled in this form, the calculation requires the subtraction $\$(375 - 318.75)$ in order to answer the question set. It was expected that candidates would calculate 15% of $\$375$ directly.

Mark awarded = 0 out of 1

- (c) (i) The candidate evaluates the required multiplication by using appropriate fraction techniques.
(ii) Similarly with the division required for this calculation.

Mark awarded = 2 out of 2

Total mark awarded = 2 out of 4

Examiner comment – grade C

- (a) Together with other possibilities, the cost price and selling price are shown in a correct relationship. This is correctly evaluated as 140% but crossed out. It could have led to the correct answer. It is not immediately clear where the 61 given as the answer has come from.

Mark awarded = 0 out of 1

- (b) There is a clear calculation showing 15% of \$425. Perhaps this is the 61 that appears in the answer space to part (a). When using \$375, the calculations involving 15% are incorrect. It seems that the ideas and data of parts (a) and (b) have got mixed up.

Mark awarded = 0 out of 1

- (c) (i) The correct multiplication is found.
(ii) Multiplication is used again when division was required.

Mark awarded = 1 out of 2

Total mark awarded = 1 out of 4

Example candidate response – grade E

- 16 (a) Dwayne buys a camera for \$90.
He sells the camera for \$126.

Calculate his percentage profit.

$$14 \frac{42}{3} \frac{126}{90} \times 100$$

Answer 140 % [1]

- (b) The price of a computer was \$375.
In a sale, the price was reduced by 15%.

Calculate the reduction in the price of the computer.

$$\begin{array}{r} 125 \\ 375 \\ \hline 500 \end{array} \times 100 = 25 \times 100 = 2500$$

$$2500 - 375 = 2225$$

Answer \$ 2225 [1]

- (c) The exchange rate between euros and dollars is €1 = \$1.25 .

- (i) Convert €180 to dollars.

$$\begin{aligned} &= 180 \times \frac{1.25}{100} &= \frac{3350}{10} \\ &= 180 \times \frac{125}{100} \end{aligned}$$

Answer \$ 33.5 [1]

- (ii) Convert \$500 to euros.

$$500 \times 1 = 500$$

Answer € 500 [1]

Examiner comment – grade E

- (a) To complete the task given, 100% should be deducted.

Mark awarded = 0 out of 1

- (b) 'Reduced by' seems to have been interpreted as 'divided by'.

Mark awarded = 0 out of 1

- (c) (i) A correct approach with incorrect arithmetic.
(ii) There is a misread of figures and an incorrect operation.

Mark awarded = 0 out of 2

Total mark awarded = 0 out of 4

Question 17

Mark scheme

17 (a)	$\begin{pmatrix} 3 \\ 1 \end{pmatrix}$	1	
(b)	$\begin{pmatrix} -1 & 0 \\ 0 & 1 \end{pmatrix}$	1	
(c)	Correct enlargement, vertices $(-1, 2), (1, 2), (1, 6)$	2	B1 for two vertices corrector for correct size and correct orientation

Example candidate response – grade A

17 The diagram shows triangles A, B and C .

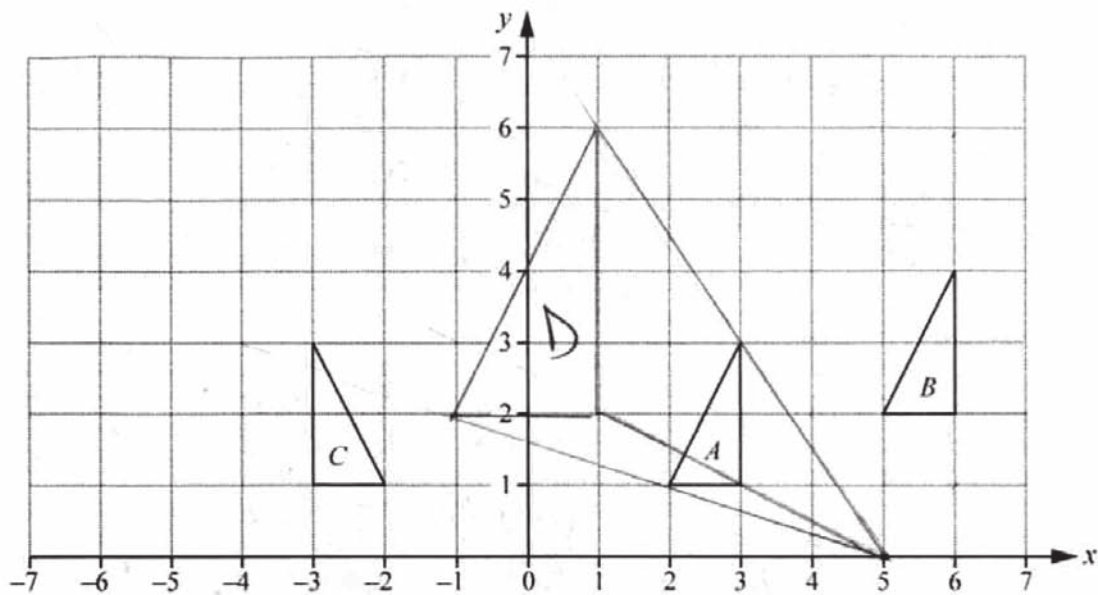

(a) Triangle A can be mapped onto triangle B by a translation.

Write down the column vector for the translation.

Answer

$$\begin{pmatrix} 3 \\ 1 \end{pmatrix}$$

[1]

(b) Find the matrix representing the transformation that maps triangle A onto triangle C .

reflection
~~(2, 1)~~
 $A = (2, 1) (3, 1) (3, 3)$
 $C = (-2, 1) (-3, 1) (-3, 3)$ Answer

$$\begin{pmatrix} 0 & -1 \\ 1 & 0 \end{pmatrix}$$

[1]

(c) Triangle A is mapped onto triangle D by an enlargement, scale factor 2, centre $(5, 0)$.

Draw and label triangle D .

[2]

Examiner comment – grade A

(a) The vector notation for translation is well understood.

Mark awarded = 1 out of 1

(b) By writing down both sets of coordinates, the candidate clearly realises that the number -1 is significant. Relying, perhaps, on memory to produce the final result proves unreliable. There is evidence that the candidate has realised that the transformation is a reflection. A practical method would then have been to reflect the two base vectors in the y -axis.

Mark awarded = 0 out of 1

(c) The candidate has used the information given to construct the triangle D .

Mark awarded = 2 out of 2

Total mark awarded = 3 out of 4

Example candidate response – grade C

17 The diagram shows triangles A, B and C.

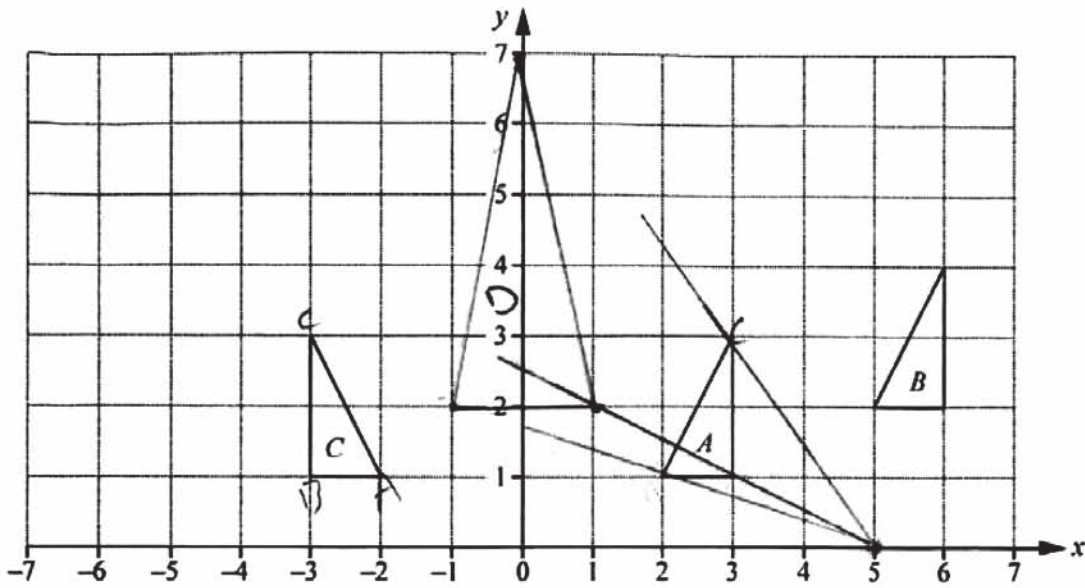

(a) Triangle A can be mapped onto triangle B by a translation.

Write down the column vector for the translation.

Answer $\begin{pmatrix} 3 \\ 1 \end{pmatrix}$ [1]

(b) Find the matrix representing the transformation that maps triangle A onto triangle C.

$a = 0$
 $c = -2$

Answer $\begin{pmatrix} 0 & 0 \\ -2 & 1 \end{pmatrix}$ [1]

(c) Triangle A is mapped onto triangle D by an enlargement, scale factor 2, centre (5,0).

Draw and label triangle D.

$1 \times \frac{2}{1} = 2$ $3 \times \frac{2}{1} = 6$ $2 \times \frac{2}{1} = 4$ [2]

$$\begin{pmatrix} a & b \\ c & d \end{pmatrix} \begin{pmatrix} 2 & 3 \\ 1 & 1 \end{pmatrix} = \begin{pmatrix} -2 & -3 \\ 1 & 1 \end{pmatrix}$$

$$\begin{matrix} 2a + c & 3a + c \\ 2b + d & 3b + d \end{matrix} = \begin{pmatrix} -2 & -3 \\ 1 & 1 \end{pmatrix}$$

$$\begin{matrix} 2a + c = -2 \\ 3a + c = -3 \\ 0 + c = -2 \\ c = -2 - 0 \\ c = -2 \end{matrix}$$

$$a = \frac{-2 - c}{2}$$

$$a = \frac{-3 - c}{3}$$

Examiner comment – grade C

(a) Ideas of translation are clear

Mark awarded = 1 out of 1

(b) The candidate attempts a long method to obtain the required matrix. The initial statement of the method is correct, but the subsequent matrix multiplication leads to some incorrect equations. Using base vectors would have been the method to apply here.

Mark awarded = 0 out of 1

(c) Had the third construction line been longer, all three vertices of triangle D may have been located correctly.

Mark awarded = 1 out of 2

Total mark awarded = 2 out of 4

Example candidate response – grade E

17 The diagram shows triangles A , B and C .

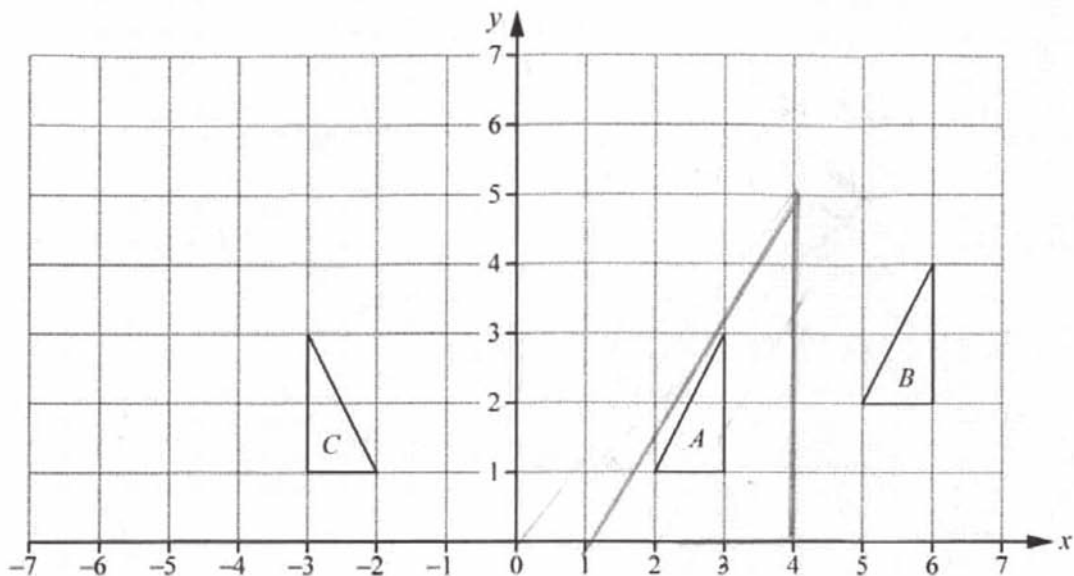

(a) Triangle A can be mapped onto triangle B by a translation.

Write down the column vector for the translation.

Answer $\begin{pmatrix} 5 \\ 2 \end{pmatrix}$ [1]

(b) Find the matrix representing the transformation that maps triangle A onto triangle C .

$$\begin{bmatrix} 2 \\ 3 \end{bmatrix} \begin{bmatrix} -3 \\ 3 \end{bmatrix}$$

$$\begin{bmatrix} 2 + 6 \\ 4 + 0 \end{bmatrix}$$

Answer $\begin{pmatrix} 8 \\ 0 \end{pmatrix}$ [1]

(c) Triangle A is mapped onto triangle D by an enlargement, scale factor 2, centre $(5, 0)$.

Draw and label triangle D .

[2]

Examiner comment – grade E

(a) The answer given is a column vector and could be a translation. The entries do not relate to the triangles given in the diagram.

Mark awarded = 0 out of 1

(b) The working indicates some attempt to combine column vectors. There is no link with the transformation that maps triangle **A** onto triangle **C**.

Mark awarded = 0 out of 1

(c) Some understanding of enlargement is shown, but the significance of the scale factor and centre are not appreciated.

Mark awarded = 0 out of 2

Total mark awarded = 0 out of 4

Question 18

Mark scheme

18 (a)	135	1	
(b) (i)	165	1FT	FT 300 – <i>their</i> (a)
(ii)	24 cao	2	M1 for $360 \div (180 - \textit{their} 165)$

Example candidate response – grade A

18 (a) Find the size of the interior angle of a regular octagon.

$$\frac{360}{8} = 45$$

$$45 + 90 = 135^\circ \quad \text{Answer } \dots\dots\dots 135^\circ \dots\dots\dots [1]$$

(b) A regular octagon, an equilateral triangle and a regular n -sided polygon fit together at a point.

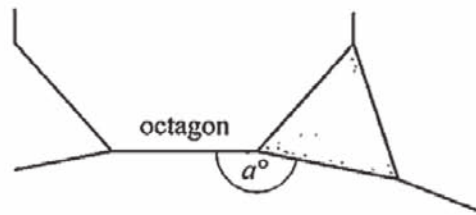

(i) An interior angle of the regular n -sided polygon is a° .

Find a .

$$\frac{180}{3} = 60$$

$$360 - (60 + 135)$$

$$360 - 195 = 165^\circ \quad \text{Answer } a = \dots\dots\dots 165^\circ \dots\dots\dots [1]$$

(ii) Find the value of n .

$$\begin{array}{r} 165 \\ \times 360 \\ \hline 19513 \end{array}$$

$$\frac{3960}{13}$$

$$\text{Answer } n = \dots\dots\dots 34 \dots\dots\dots [2]$$

Examiner comment – grade A

(a) An accurate approach by way of the external angle of the regular octagon.

Mark awarded = 1 out of 1

(b) (i) This candidate works out the angle of the equilateral triangle, and then sets out clearly the relevant expression based on the sum of the angles at a point.

(ii) The candidate now needs to take 165° as the starting point and revisit the procedure seen in part (a) to work back to the required number of sides. It is not clear here what the candidate had in mind by forming the ratio $\frac{165}{195}$ and evaluating a proportion of 360° .

Mark awarded = 1 out of 3

Total mark awarded = 2 out of 4

Example candidate response – grade C

18 (a) Find the size of the interior angle of a regular octagon.

Answer 130° [1]

(b) A regular octagon, an equilateral triangle and a regular n -sided polygon fit together at a point.

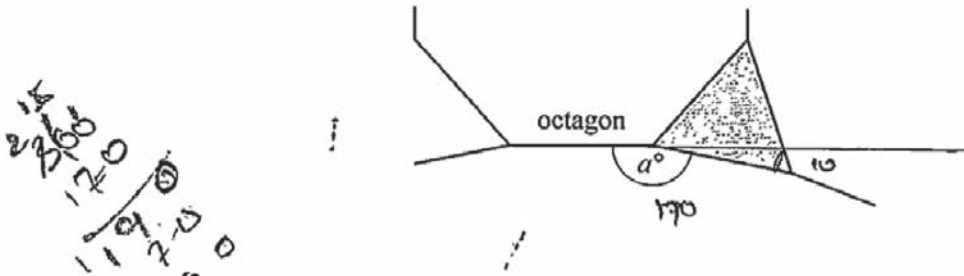

(i) An interior angle of the regular n -sided polygon is a° .

Find a .

Answer $a =$ 170° [1]

(ii) Find the value of n .

$$\begin{array}{r} 170 \times 5 \\ \hline + 80 \\ \hline 920 \end{array}$$

Answer $n =$ [2]

Examiner comment – grade C

(a) This could be a near miss by memory or estimation. Either way, there is a need to understand the basic principles behind the recognised formulae.

Mark awarded = 0 out of 1

- (b) (i) The angle of the equilateral triangle and the idea of angles at a point have been used successfully.
- (ii) There is no indication of the thinking giving rise to this calculation. Again, probably a case for understanding principles rather than remembering formulae.

Mark awarded = 1 out of 3

Total mark awarded = 1 out of 4

Example candidate response – grade E

18 (a) Find the size of the interior angle of a regular octagon.

$$\frac{(n-2) \times 180}{8} = \frac{6 \times 180}{8} = \frac{1080}{8}$$

Answer 80 [1]

(b) A regular octagon, an equilateral triangle and a regular n -sided polygon fit together at a point.

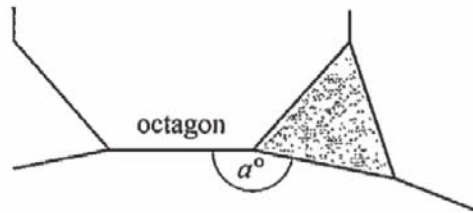

(i) An interior angle of the regular n -sided polygon is a° .

Find a .

Answer $a =$ 180 [1]

(ii) Find the value of n .

$$\frac{(8-2) \times 180}{6 \times 180}$$

Answer $n =$ 116 [2]

Examiner comment – grade E

(a) A correct formula is quoted. The substitution omits the brackets but the correct calculation survives. A correct evaluation at this point would have gained the mark.

Mark awarded = 0 out of 1

(b) (i) The value obtained in the previous part is not related to the new situation. There is no reference to angles at a point.

(ii) It is not clear what the candidate is hoping to achieve with this calculation.

Mark awarded = 0 out of 3

Total mark awarded = 0 out of 4

Question 19

Mark scheme

19 (a) (i)	6	1	
(ii)	3	1	
(b)	$\frac{16b^6}{a^2}$ or $16b^6a^{-2}$	2	B1 for answer with 16 in numerator or for two out of three terms algebraically correct Or B1 for $\frac{(1)a}{4b^3}$ or better seen

Example candidate response – grade A

19 (a) Evaluate

(i) $\sqrt[3]{216}$,

$$6 \times 6 \times 6 \quad \begin{array}{r} 3 \quad 3 \quad 6 \\ 6 \\ \hline 216 \end{array}$$

$$\therefore = 36 \times 6$$

$$= 216$$

Answer 6 [1]

(ii) $16^{\frac{1}{2}} - 16^0$.

$$\sqrt{16} - 1$$

$$4 - 1$$

$$= 3$$

$$4 \times 6$$

$$= 24$$

$$= 6^3$$

Answer 3 [1]

(b) Simplify $\left(\frac{3a^2b}{12ab^4}\right)^{-2}$.

$$\left(\frac{1a^{2-1}b^{1-4}}{4}\right)^{-2}$$

$$\left(\frac{ab^{-3}}{4}\right)^{-2}$$

$$= \left(\frac{4a}{b^3}\right)^2$$

$$= \frac{16a^2}{b^6}$$

Answer $\frac{16a^2}{b^6}$ [2]

Examiner comment – grade A

- (a) (i) The working seems to suggest that the candidate had a good idea of the correct answer and was verifying it.
- (ii) The necessary theory of indices is well understood.

Mark awarded = 2 out of 2

- (b) The candidate adopts the most appropriate strategy here and successfully simplifies the expression inside the brackets, arriving at $\frac{ab^{-3}}{4}$, which is equivalent to the expression shown in the scheme. In dealing with the negative powers -3 and -2 at the same time in the next step, the resulting a^2 and b^6 have ended up in reverse positions in the final fraction.

Mark awarded = 1 out of 2

Total mark awarded = 3 out of 4

Example candidate response – grade C

19 (a) Evaluate

(i) $\sqrt[3]{216}$,

Answer ~~216~~ 6 [1]

(ii) $16^{\frac{1}{2}} - 16^{\frac{0}{2}}$

16×0

Answer 0 [1]

(b) Simplify $\left(\frac{3a^2b}{12ab^4}\right)^{-2}$.

$\left[\frac{3^1 a^2}{4^1 b^4}\right]^{-2}$ $\left[\frac{a}{4b^3}\right]^{-2}$

Answer ~~$\frac{3a^2}{4b^4}$~~ $\left[\frac{a}{4b^3}\right]^{-2}$ [2]

Examiner comment – grade C

- (a) (i) A check seems to confirm to the candidate that this is the correct result.
 (ii) This solution seems to be an instance of $16 \times \frac{1}{2} - 0$. These were common errors.

Mark awarded = 1 out of 2

- (b) This is correct as far as it goes, and clearly in the candidate's view, it is now simpler than it was at the start. There is a need to appreciate fully what 'Simplify' means in this context.

Mark awarded = 1 out of 2

Total mark awarded = 2 out of 4

Example candidate response – grade E

19 (a) Evaluate

(i) $\sqrt[3]{216}$,

$$\begin{array}{r} 6 \\ 2 \overline{) 12} \\ \underline{12} \\ 2 \overline{) 216} \\ \underline{216} \\ \times \end{array}$$

$$\frac{18}{18} = 4$$

$$\frac{64}{256}$$

$$\frac{13}{39} = \frac{13}{39} \times$$

Answer 6 [1]

(ii) $16^{\frac{1}{2}} - 16^0$.

$$(4)^{2 \times \frac{1}{2}} - 1$$

$$4 - 1$$

$$23 \frac{24}{24}$$

Answer 3 [1]

(b) Simplify $\left(\frac{3a^2b}{12ab^4}\right)^{-2}$.

$$\left(\frac{12ab^4}{3a^2b}\right)^2$$

$$\frac{24a^2b^8}{9a^4b^2}$$

Answer $\frac{24a^2b^8}{9a^4b^2}$ [2]

Examiner comment – grade E

- (a) (i) The significance of the trial calculations is not clear. They were probably not used.
- (ii) The evaluation of $16^{\frac{1}{2}}$ shows a good grasp of the theory of indices.

Mark awarded = 2 out of 2

- (b) A correct adjustment is made in the change over from the power -2 to the power 2 . The answer 24 is a clear mistake, but if the candidate had simplified the terms in (a) and (b), some credit could have been obtained.

Mark awarded = 0 out of 2

Total mark awarded = 2 out of 4

Question 20

Mark scheme

20	(a)	$\frac{v}{25}$	1	B1 for any correct expression for one area
	(b)	10	2	
	(c)	108	1 FT	

Example candidate response – grade A

- 20 The diagram shows the speed-time graph for 100 seconds of a car's journey. The car accelerates uniformly from a speed of v m/s to a speed of $3v$ m/s in 50 seconds. It then continues at a constant speed.

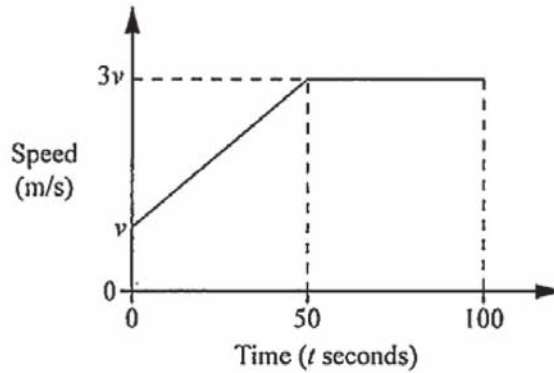

- (a) Find, in terms of v , the acceleration of the car in the first 50 seconds.

$$\frac{2v}{50} = \frac{v}{25}$$

Answer $\frac{v}{25}$ m/s² [1]

- (b) The car travels 2500 metres during the 100 seconds.

Find v .

$s = \frac{d}{t}$

$$\frac{1}{2} \times 2 \times 50v + 3v \times 50 = 2500$$

$$50v + 150v = 2500$$

$$200v = 2500$$

$$v = 10$$

Answer $v = 10$ [2]

- (c) Find the speed of the car, in kilometres per hour, when $t = 75$.

$$\frac{30 \times 3600}{1000}$$

$$\frac{30 \times 3600}{1000} = 108$$

Answer 108 km/h [1]

Examiner comment – grade A

- (a) The candidate reads the appropriate changes in speed and time from the graph and simplifies the ratio required to express the acceleration.

Mark awarded = 1 out of 1

- (b) The complete area under the speed-time graph is clearly divided into two rectangles and a triangle, leading to the equation for the distance. This is solved accurately.

Mark awarded = 2 out of 2

- (c) The speed required, 30 metres per second, is correctly converted to kilometres per hour by means of the multiplying factor $\frac{60 \times 60}{1000}$.

Mark awarded = 1 out of 1

Total mark awarded = 4 out of 4

Example candidate response – grade C

- 20 The diagram shows the speed-time graph for 100 seconds of a car's journey. The car accelerates uniformly from a speed of v m/s to a speed of $3v$ m/s in 50 seconds. It then continues at a constant speed.

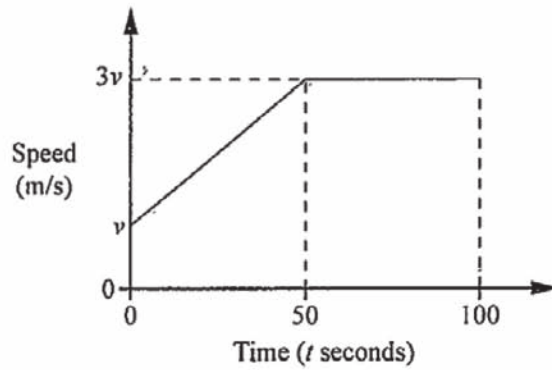

- (a) Find, in terms of v , the acceleration of the car in the first 50 seconds.

$$\frac{v - 3v}{50} = \frac{-2v}{25}$$

Answer $v = 25$ m/s² [1]

- (b) The car travels 2500 metres during the 100 seconds.

Find v .

$$\frac{2500}{100} = \frac{v - 2500}{100}$$

$$v = 25$$

Answer $v = 25$ [2]

- (c) Find the speed of the car, in kilometres-per hour, when $t = 75$.

Speed = $\frac{\text{distance}}{\text{time}}$

$$\frac{2500}{75} = 33.3$$

$$\begin{array}{r} 33.3 \\ 3 \overline{) 100} \\ \underline{9} \\ 10 \\ \underline{9} \\ 10 \end{array}$$

Answer 33.3 km/h [1]

Examiner comment – grade C

(a) The general idea of gradient is clear, but this needs to be related to the situation as given in the graph.

Mark awarded = 0 out of 1

(b) No account is taken of the area under the speed-time graph.

Mark awarded = 0 out of 2

(c) Again, the situation described by the graph is not taken into account. The graph shows that the speed required is $3v$.

Mark awarded = 0 out of 1

Total mark awarded = 0 out of 4

Example candidate response – grade E

- 20 The diagram shows the speed-time graph for 100 seconds of a car's journey. The car accelerates uniformly from a speed of v m/s to a speed of $3v$ m/s in 50 seconds. It then continues at a constant speed.

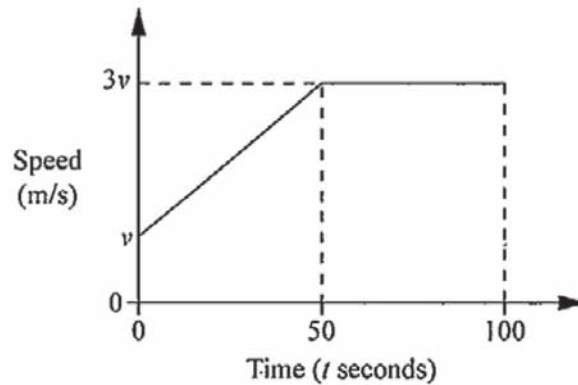

- (a) Find, in terms of v , the acceleration of the car in the first 50 seconds.

$$\frac{v - u}{t} \quad \frac{3v}{50} \neq 3 \text{ m/s}$$

Answer 150 m/s^2 [1]

- (b) The car travels 2500 metres during the 100 seconds.

Find v .

$$\frac{2500}{100}$$

Answer $v =$ 25 [2]

- (c) Find the speed of the car, in kilometres per hour, when $t = 75$.

Answer 18.75 km/h [1]

Examiner comment – grade E

(a) The working indicates that the candidate is looking for the change of speed with respect to time. An accurate reading of the graph would have given $3v - v$. This candidate goes on to assume that an equation had to be solved at this point. This was a common error.

Mark awarded = 0 out of 1

(b) This was a common wrong answer. The area under the speed-time graph has been ignored.

Mark awarded = 0 out of 2

(c) A correct conversion using 3×25 would have gained this mark. As it is, no working is shown.

Mark awarded = 0 out of 1

Total mark awarded = 0 out of 3

Question 21

Mark scheme

21 (a)	$\frac{7}{10}, \frac{7}{9}, \frac{3}{9}, \frac{6}{9}$ correctly completed	1	
(b) (i)	$\frac{1}{15}$	1	
(ii)	$\frac{7}{15}$ FT	2	B1 for $\frac{21}{90}$ oe FT Or M1 for $\frac{3}{10} \times \frac{7}{9} + \frac{7}{10} \times \frac{3}{9}$

Examiner comment – grade A

- (a) The tree diagram is completed correctly. Some of the probabilities are simplified. In this case, the new fractions are clear, but occasionally this can result in candidates misreading their figures in later parts of the question.

Mark awarded = 1 out of 1

- (b) (i) The required probability is found and expressed as a fraction in its lowest terms.
(ii) The method shown for the required probability is correct, but a mistake occurs in combining the fractions. Perhaps if the probability shown on the tree had been left as $\frac{3}{9}$ this error may have been avoided.

Mark awarded = 2 out of 3

Total mark awarded = 3 out of 4

Examiner comment – grade C

(a) The tree diagram is completed correctly. The probabilities are left in an unsimplified form.

Mark awarded = 1 out of 1

(b) (i) This combined event is understood.
 (ii) The working does not show the appropriate theory for this combined event.

Mark awarded = 1 out of 3

Total mark awarded = 2 out of 4

Example candidate response – grade E

21 Luis has 3 black pens and 7 red pens in a case. He takes two pens from the case at random without replacement.

(a) Complete the tree diagram to show the possible outcomes and their probabilities.

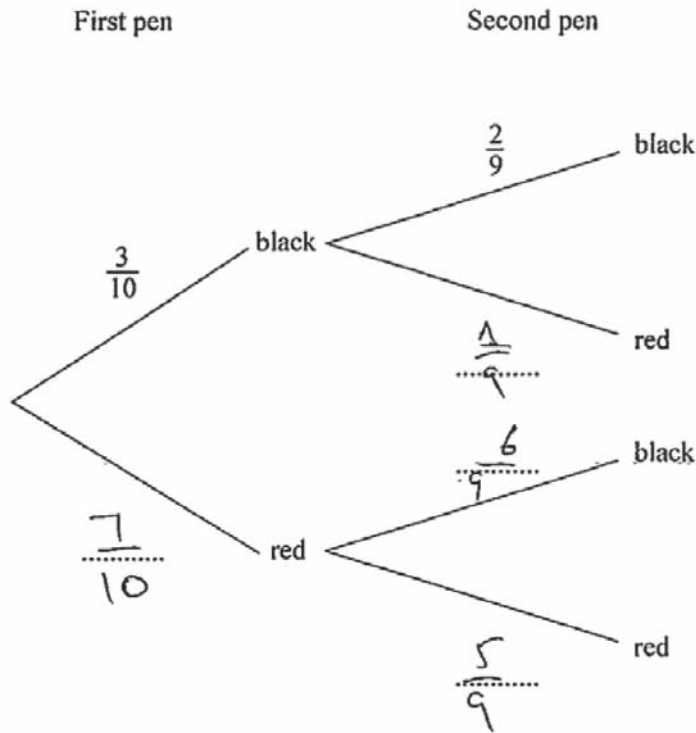

[1]

(b) Find, as a fraction in its lowest terms, the probability that

(i) Luis takes two black pens,

$$\frac{3}{10} \times \frac{2}{9}$$

Answer $\frac{2}{30}$ [1]

(ii) Luis takes two different coloured pens.

$$\frac{7}{10} \times \frac{3}{10} = \frac{21}{100}$$

Answer $\frac{21}{100}$ [2]

Examiner comment – grade E

- (a) The probabilities for the second pen are expressed in ninths, but the number of pens of each colour remaining at each stage, are incorrect.

Mark awarded = 0 out of 1

- (b) (i) The situation regarding two black pens is interpreted correctly.
(ii) The candidate chooses two probabilities from the branches dealing with the first pen only. Parts (a) and (b) together seem to indicate that the sequence of events implied by a tree diagram is not fully appreciated.

Mark awarded = 1 out of 3

Total mark awarded = 1 out of 4

Question 22

Mark scheme

22 (a)	9	2	B1 for $\sqrt{15^2 - 12^2}$
(b)	279	2FT	B1 for $0.5 \times \text{their } 9 \times 12$ B1 for $(\text{their } 9)^2 + 12^2$

Example candidate response – grade A

- 22 Shape $ABCDEFG$ is made from two squares and a right-angled triangle.
 $AB = 15$ cm and $BC = 12$ cm.

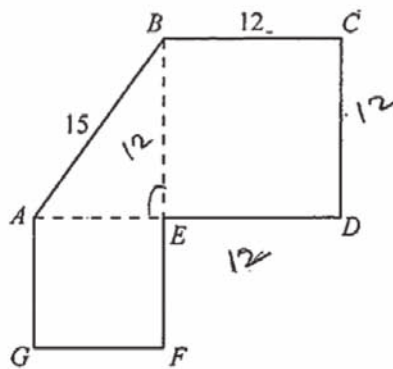

- (a) Find the length AG .

$$\begin{aligned}
 H^2 &= B^2 + P^2 \\
 (15)^2 &= B^2 + (12)^2 \\
 225 &= B^2 + 144 \\
 225 - 144 &= B^2 \\
 B^2 &= 81 \\
 \sqrt{B^2} &= \sqrt{81} \\
 B &= 9 \\
 AE = AG &= 9
 \end{aligned}$$

Answer 9 cm [2]

$$\begin{array}{r}
 2/15 \\
 \underline{15} \\
 75 \\
 15 \times 12 \\
 \underline{120} \\
 144 \\
 \underline{81}
 \end{array}$$

- (b) Find the total area of the shape.

$$\begin{aligned}
 A &= L \times b \\
 &= 12 \times 12 \\
 &= 144
 \end{aligned}$$

$$\begin{aligned}
 A &= \frac{1}{2} \times b \times H \\
 &= \frac{1}{2} \times 12 \times 9 \\
 &= 6 \times 9 \\
 &= 54
 \end{aligned}$$

$$\begin{aligned}
 A &= L \times b \\
 &= 9 \times 9 \\
 &= 81
 \end{aligned}$$

Total Area = $81 + 54 + 144$

Answer 279 cm² [2]

$$\begin{array}{r}
 144 \\
 81 \\
 \underline{54} \\
 279
 \end{array}$$

Examiner comment – grade A

(a) The properties of the square are used effectively to reach the correct answer via Pythagoras’s theorem.

Mark awarded = 2 out of 2

(b) The total area of the shape is clearly given as the sum of two squares and a triangle.

Mark awarded = 2 out of 2

Total mark awarded = 4 out of 4

Example candidate response – grade C

22 Shape $ABCDEFG$ is made from two squares and a right-angled triangle.
 $AB = 15$ cm and $BC = 12$ cm.

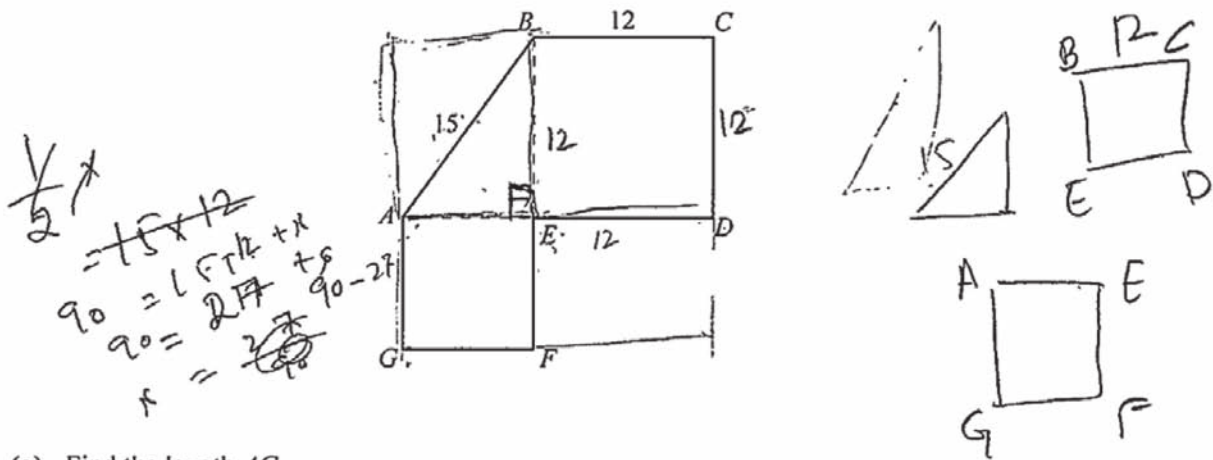

(a) Find the length AG .

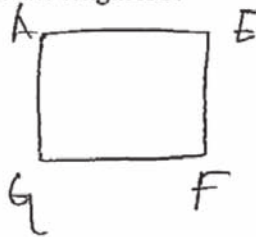

6cm because its a half of upper one square that's why

Answer 6 cm [2]

(b) Find the total area of the shape.

$$\begin{aligned}
 \text{Area} &= (l \times l) + \frac{1}{2} \times b \times h + l \times l \\
 &= 12 \times 12 + \frac{1}{2} \times 15 \times 12 + 6 \times 6 \\
 &= 144 + 85 + 36
 \end{aligned}$$

Answer 260 cm² [2]

Examiner comment – grade C

(a) The candidate highlights the right angled triangle shown dotted in the diagram on the paper. This does not lead the solution in the direction of Pythagoras’s theorem, however.

Mark awarded = 0 out of 2

(b) The solution appreciates the fact that the given area consists of two squares. $\frac{1}{2} \times 15 \times 12$ was a common error for the triangular area.

Mark awarded = 1 out of 2

Total mark awarded = 1 out of 4

Example candidate response – grade E

22 Shape *ABCDEFGG* is made from two squares and a right-angled triangle.
AB = 15 cm and *BC* = 12 cm.

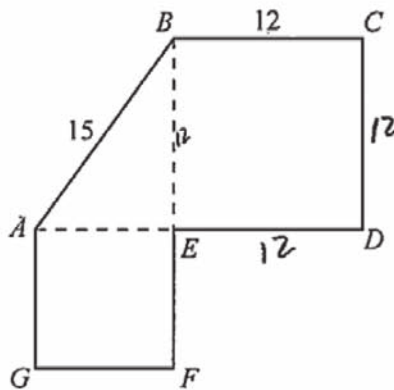

(a) Find the length *AG*.

$$15 - 12 = 3$$

Answer 3cm [2]

(b) Find the total area of the shape.

$$\begin{aligned}
 \text{E} \times \text{D} &= 12 \times 12 = 144 \\
 \text{L} \times \text{D} &= 3 \times 3 = 9 \\
 \frac{1}{2} \times \text{b} \times \text{h} &= \frac{1}{2} \times 15 \times 3 = 90
 \end{aligned}$$

$$\begin{aligned}
 &144 \\
 &+ 9 \\
 &+ 90 \\
 \hline
 &243
 \end{aligned}$$

Answer 243cm² [2]

Examiner comment – grade E

(a) This error was made occasionally. No account has been taken of the right angled triangle.

Mark awarded = 0 out of 2

(b) The solution takes account of the two squares. Using 15 in the formula for the area of a triangle was a common error.

Mark awarded = 1 out of 2

Total mark awarded = 1 out of 4

Question 23

Mark scheme

23 (a)	$2x^2 + 9x + 4$	1	
(b)	$\frac{7x + 6}{x(x + 2)}$ final answer	1	
(c)	2 or -5	3	<p>B2 for $(x - 2)(x + 5) = 0$</p> <p>Or $\frac{-3 \pm \sqrt{49}}{2}$</p> <p>B1 for $x^2 + 3x - 10 = 0$ or 3 term equation or $x^2 + 3x - 10$</p>

Example candidate response – grade A

- 23 (a) Expand and simplify $(2x+1)(x+4)$.

$$\begin{aligned} 2x(x+4) + 1(x+4) \\ 2x^2 + 8x + x + 4 \\ 2x^2 + 9x + 4 \end{aligned}$$

Answer $2x^2 + 9x + 4$ [1]

- (b) Write $\frac{3}{x} + \frac{4}{x+2}$ as a single fraction in its simplest form.

$$\begin{aligned} \frac{3(x+2) + 4x}{x(x+2)} \\ \frac{3x + 6 + 4x}{x^2 + 2x} \end{aligned}$$

$$\frac{7x + 6}{x^2 + 2x}$$

Answer $\frac{7x + 6}{x^2 + 2x}$ [1]

- (c) Solve $\frac{10}{x} = x + 3$.

$$\begin{aligned} 10 &= x(x+3) \\ 10 &= x^2 + 3x \\ x^2 + 3x - 10 &= 0 \\ x^2 + 5x - 2x - 10 &= 0 \\ x(x+5) - 2(x+5) &= 0 \\ (x+5)(x-2) &= 0 \\ x &= -5 \quad x = 2 \end{aligned}$$

$$\begin{array}{r|l} 2 & 10 \\ 5 & 5 \\ \hline & 1 \end{array}$$

Answer $x = -5$ or 2 [3]

Examiner comment – grade A

- (a) The candidate shows how the expansion is obtained, and clearly understands that simplify means that like terms have to be grouped together.

Mark awarded = 1 out of 1

- (b) The fractions are correctly combined. The numerator is expanded and simplified by grouping like terms. The candidate chooses to show the denominator as the sum of its terms rather than in factorised form. This was considered to be equally acceptable.

Mark awarded = 1 out of 1

- (c) The candidate finds the relevant quadratic equation, and solves it by factorisation.

Mark awarded = 3 out of 3

Total mark awarded = 5 out of 5

Example candidate response – grade C

23 (a) Expand and simplify $(2x+1)(x+4)$.

$$= 2x^2 + 8x + x + 4$$

$$2x^2 + 8x + x + 4$$

$$\left. \begin{array}{l} 2x^2 + 9x + 4 \\ 2x^2 + 8x + x + 4 \\ 2x(x+4)(x+4) \end{array} \right\} \text{Answer } \dots (x+4)(2x+1) \dots [1]$$

(b) Write $\frac{3}{x} + \frac{4}{x+2}$ as a single fraction in its simplest form.

$$\frac{3}{x} + \frac{4}{x+2}$$

$$= \frac{3x+6+4x}{x(x+2)}$$

$$= \frac{7x+6}{x^2+2x}$$

Answer ~~7x+6~~ $\frac{7x+6}{x^2+2x}$ $\frac{7x+6}{x(x+2)}$ [1]

(c) Solve $\frac{10}{x} = x+3$.

$$10 = x^2 + 3x$$

$$\Rightarrow 10 - x^2 = 3x$$

$$\Rightarrow -x^2 + 3x - 10 = 0$$

$$\Rightarrow -x^2 + 3x - 10 = 0$$

$$\Rightarrow 10 - 5x + 6x = 3$$

$$\Rightarrow 10 - 5x + 6x = 3$$

Answer $x = \dots (2-x) \dots$ or $\dots (5+3) \dots$ [3]

Examiner comment – grade C

(a) The required expansion and simplification is shown. There is no need to continue working beyond this point.

Mark awarded = 1 out of 1

(b) The numerator of the combined fraction is formed, but the denominator is never established.

Mark awarded = 0 out of 1

(c) In removing fractions, 10 and x^2 are reached, but not $3x$. This was a common error.

Mark awarded = 0 out of 3

Total mark awarded = 1 out of 5

Example candidate response – grade E

23 (a) Expand and simplify $(2x+1)(x+4)$.

$$= 2x^2 + 8x + x + 4$$

$$= 2x^2 + 9x + 4$$

Answer $2x^2 + 9x + 4$ [1]

(b) Write $\frac{3}{x} + \frac{4}{x+2}$ as a single fraction in its simplest form.

$$= \frac{x(3) + x+2(4)}{x(x+2)} = \frac{3x + x + 8}{x^2 + 2} = \frac{4x + 8}{x^2 + 2}$$

$$= \frac{4x + 8}{x^2 + 2}$$

Answer $\frac{4x + 8}{x^2}$

(c) Solve $\frac{10}{x} = x + 3$.

$$10 = x(x+3)$$

$$10 = x^2 + 3x$$

$$10 - 3 = x^2$$

$$\sqrt{7} = \sqrt{x^2}$$

$$x = 2.6$$

<p>①</p> $\begin{array}{r} 2.7 \\ 2.7 \\ \hline 189 \\ 39 \times \\ \hline 729 \end{array}$	<p>②</p> $\begin{array}{r} 2.5 \\ 2.5 \\ \hline 125 \\ 50 \times \\ \hline 625 \end{array}$
	<p>③</p> $\begin{array}{r} 2.6 \\ 2.6 \\ \hline 156 \\ 82 \times \\ \hline 676 \end{array}$

Answer $x = 2.6$ or 2.6 something [3]

Examiner comment – grade E

(a) The solution demonstrates that the demand, expand and simplify, is fully understood.

Mark awarded = 1 out of 1

(b) A correct common denominator is found. However, the candidate attempts to combine the two fractions incorrectly. Thereafter, there are incorrect ideas of multiplication and cancelling.

Mark awarded = 0 out of 1

(c) After a correct transposition containing brackets, the three term quadratic expression is not retained.

Mark awarded = 0 out of 3

Total mark awarded = 1 out of 5

Question 24

Mark scheme

24 (a)	Correct frequency polygons drawn	3	Consisting of these marks which can be awarded singly: B1 for linear scale up to 8 on frequency axis B1 for plots at correct heights B1 for plotting their points at centre of interval and joined with ruled lines
(b)	$1 < t \leq 1.5$	1	
(c)	Correct comment(s) making a comparison of times between girls and boys.	1	E.g. The mode for the boys is higher than the mode for the girls The range of times was longer for boys than for girls. Most girls spent between 1 and 2 hours, but boys times more evenly spread between 0 and 3 hours

Example candidate response – grade A

- 24 Some students were asked how long they had each spent doing homework the day before. The results are summarised in the table.

Time (t hours)	$0 < t \leq 0.5$	$0.5 < t \leq 1$	$1 < t \leq 1.5$	$1.5 < t \leq 2$	$2 < t \leq 2.5$	$2.5 < t \leq 3$
Girls	0	5	8	6	0	1
Boys	3	3	4	5	3	2

- (a) On the grid, draw a frequency polygon to represent this information for the girls and another frequency polygon for the boys.

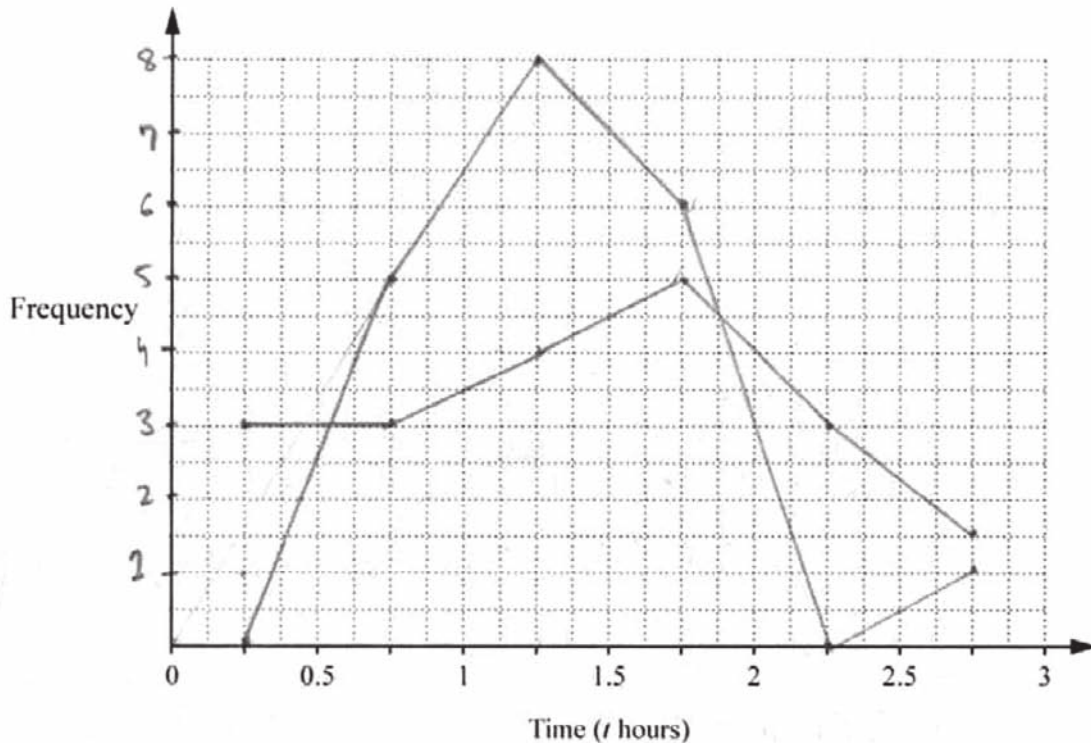

[3]

- (b) Write down the modal group for the girls.

Answer $1 < t \leq 1.5$ [1]

- (c) Make a comment comparing the distribution of the times spent by the girls with the times spent by the boys.

Answer

Time spent by girls is more than the time spent by boys. [1]

Examiner comment – grade A

- (a) Both graphs are clearly displayed on the same grid, so that comparisons between the distributions can be made. A sensible scale is chosen in order to use the full grid. The one misplot of a height does not affect the mark in this case.

Mark awarded = 3 out of 3

- (b) The modal group for the girls is expressed correctly.

Mark awarded = 1 out of 1

- (c) The comment given here does not compare the distributions. The prompt given by the previous part of the question to compare the modal groups for boys and girls is not taken up.

Mark awarded = 0 out of 1

Total mark awarded = 4 out of 5

Example candidate response – grade C

24 Some students were asked how long they had each spent doing homework the day before. The results are summarised in the table.

Time (t hours)	$0 < t \leq 0.5$	$0.5 < t \leq 1$	$1 < t \leq 1.5$	$1.5 < t \leq 2$	$2 < t \leq 2.5$	$2.5 < t \leq 3$
Girls	0	5	8	6	0	1
Boys	3	3	4	5	3	2

(a) On the grid, draw a frequency polygon to represent this information for the girls and another frequency polygon for the boys.

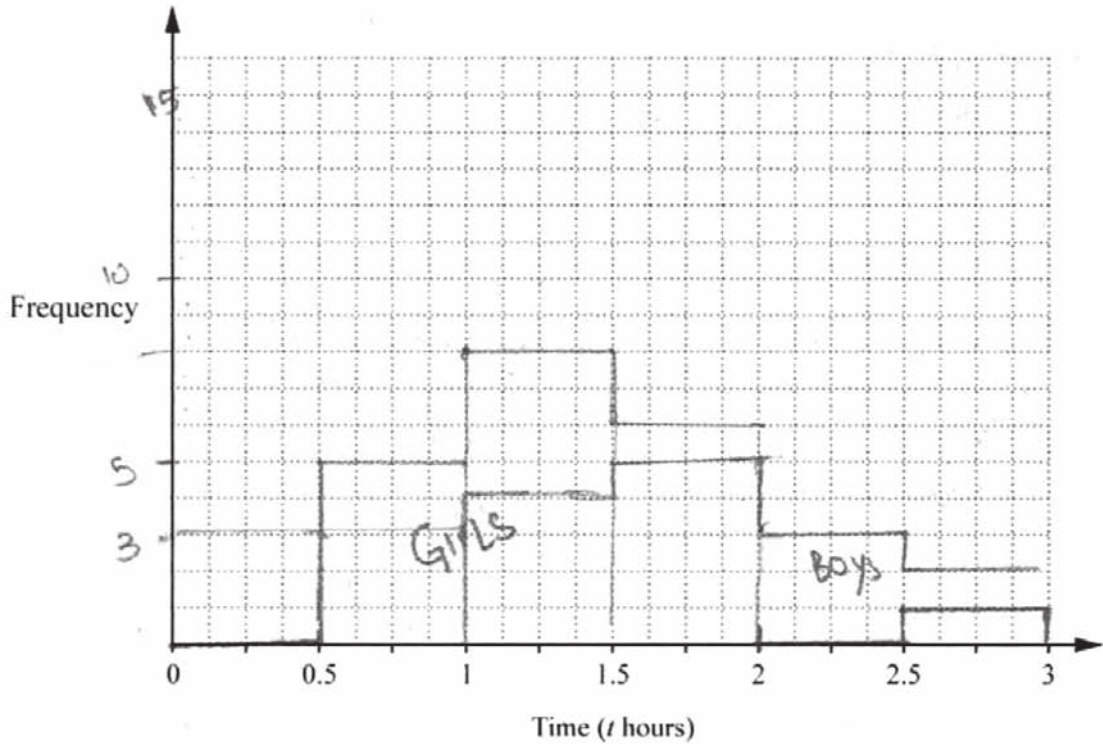

[3]

(b) Write down the modal group for the girls.

Answer 8 / $1 < t \leq 1.5$ [1]

(c) Make a comment comparing the distribution of the times spent by the girls with the times spent by the boys.

Answer

..... girls spent more time than boys especially when time was 1 to 1.5, there were many girls but few boys [1]

Examiner comment – grade C

- (a) The scale is correctly, if unusually, indicated on the frequency axis. There are no points plotted. Bar charts did not score any further marks.

Mark awarded = 1 out of 3

- (b) A choice of answers is given here.

Mark awarded = 0 out of 0

- (c) It was felt that statements such as ‘The girls spent more time than the boys’ were not strictly justified by the information given. This candidate seems to be moving towards comparing the modes of the two distributions.

Mark awarded = 0 out of 1

Total mark awarded = 1 out of 5

Example candidate response – grade E

24 Some students were asked how long they had each spent doing homework the day before. The results are summarised in the table.

Time (t hours)	$0 < t \leq 0.5$	$0.5 < t \leq 1$	$1 < t \leq 1.5$	$1.5 < t \leq 2$	$2 < t \leq 2.5$	$2.5 < t \leq 3$
Girls	0	5	8	6	0	1
Boys	3	3	4	5	3	2

(a) On the grid, draw a frequency polygon to represent this information for the girls and another frequency polygon for the boys.

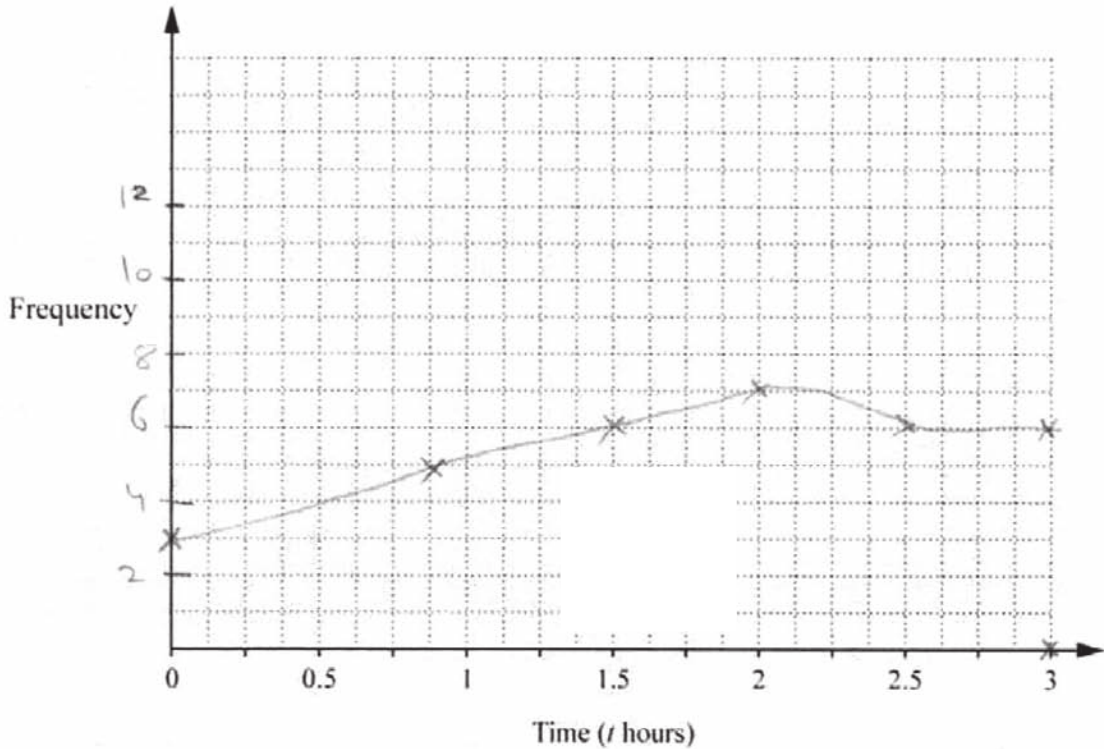

[3]

(b) Write down the modal group for the girls.

1.5 - 2 Ans

Answer 8 [1]

(c) Make a comment comparing the distribution of the times spent by the girls with the times spent by the boys.

Answer

..... girls time is higher than the boys [1]

Examiner comment – grade E

(a) The frequency axis is scaled correctly. There seems to have been an attempt here to combine two graphs into one.

Mark awarded = 1 out of 3

(b) The mode has been stated rather than the modal interval.

Mark awarded = 0 out of 1

(c) This may have been an attempt to compare the modes of the two distributions. To be accepted as such, greater precision was expected.

Mark awarded = 0 out of 1

Total mark awarded = 1 out of 5

Question 25

Mark scheme

25 (a)	$(2y + x) + (3y + x) + (2y + 10) + (3x + 5) = 360$	1	
(b)	$x = 20, y = 35$	3	<p>B2 for one correct with supporting working Or M1 for correct method to eliminate one variable, condoning one arithmetic slip ,</p> <p>Or correct substitution to obtain an equation in one variable and A1ft for correct evaluation to find the other variable Or SC1 After 0 scored, for correct substitution and evaluation to find the other variable</p>
(c)	65 cao	1	

Example candidate response – grade A

25 In quadrilateral $ABCD$

$$\begin{aligned} \text{angle } A &= (2y + x)^\circ \\ \text{angle } B &= (3y + x)^\circ \\ \text{angle } C &= (2y + 10)^\circ \\ \text{angle } D &= (3x + 5)^\circ \end{aligned}$$

(a) By finding the sum of the angles in the quadrilateral, show that $7y + 5x = 345$.

$$2y + x + 3y + x + 2y + 10 + 3x + 5 = 360.$$

$$7y + 5x + 15 = 360.$$

$$7y + 5x = 360 - 15$$

$$7y + 5x = 345 \quad [1]$$

(b) Given that angle $A = 90^\circ$ then $2y + x = 90$.

Solve the simultaneous equations to find x and y .

$$7y + 5x = 345$$

$$2y + x = 90$$

$$5(2y + x = 90)$$

$$10y + 5x = 450.$$

$$\begin{array}{r} \oplus 7y \oplus 5x = 345 \\ \hline \oplus 10y \oplus 5x = 450 \\ \hline \oplus 3y = 105 \end{array}$$

$$y = \frac{105}{3}$$

$$y = 35.$$

$$2(35) + x = 90.$$

$$70 + x = 90$$

$$x = 90 - 70$$

$$x = 20.$$

$$\text{Answer } x = \underline{20} \dots\dots\dots [3]$$

$$y = \underline{35} \dots\dots\dots [3]$$

(c) Find the size of the smallest angle in the quadrilateral.

$$2(35) + 10 = 80.$$

$$\text{Answer } \underline{\text{Angle C}} \dots\dots\dots [1]$$

Examiner comment – grade A

- (a) The sum of the four angles of the quadrilateral is clearly stated to be 360° . The required equation is correctly derived.

Mark awarded = 1 out of 1

- (b) Coefficients are equalised and one variable is correctly eliminated. Had this value been evaluated correctly, full marks would have been obtained.

Mark awarded = 2 out of 3

- (c) This mark was awarded only for the correct answer of 65° . Notice that the question asked for the size of the smallest angle. It was expected that the answer space would contain a numerical value.

Mark awarded = 0 out of 1

Total mark awarded = 3 out of 5

Example candidate response – grade C

25 In quadrilateral ABCD

- angle A = $(2y + x)^\circ$
- angle B = $(3y + x)^\circ$
- angle C = $(2y + 10)^\circ$
- angle D = $(3x + 5)^\circ$

(a) By finding the sum of the angles in the quadrilateral, show that $7y + 5x = 345$.

Handwritten work for part (a):

$(3x+5) + (3y+x) + (2y+10) + (2y+x)$
 $6x + 8y + 15 = 360$
 $6x + 8y = 345$
 1345
 1580

Other notes: "put 185 in eqn 1", "put y in eqn 1", "682", "370 + x = 90", "x = 90 - 370", "x = -280", "345", "x 2", "690".

(b) Given that angle A = 90° then $2y + x = 90$.

Solve the simultaneous equations to find x and y.

$$\begin{aligned} 7y + 5x &= 345 \\ 2y + x &= 90 \end{aligned}$$

multiply 5 with eqn 2

$$\begin{aligned} 7y + 5x &= 345 \\ 10y + 5x &= 900 \\ \hline -3y &= -555 \\ y &= \frac{555}{3} \\ &= 185 \end{aligned}$$

Answer $x = -280$
 $y = 185$ [3]

(c) Find the size of the smallest angle in the quadrilateral.

Answer Angle A ~~is~~ B [1]

Handwritten calculations:

$\frac{185 \times 2}{370}$
 $\frac{185 \times 5}{925}$
 $\frac{1295}{370 - 90}$

Handwritten calculation:

$\frac{270}{280}$

Handwritten calculations:

$2(185) + x = 90$
 $370 + x = 90 - 370$
 $x = 90 - 370$
 $x = -280$
 $\frac{345}{x 2}$
 690

Handwritten calculations:

$7(185) + 5x = 345$ [1]
 $1295 + 5x = 345$
 $5x = 345 - 1295$
 $5x = -950$
 $x = -190$

Examiner comment – grade C

(a) There is no reference to the angle sum of a quadrilateral.

Mark awarded = 0 out of 1

(b) Coefficients are correctly equalised, but an arithmetic error occurs along the way. The incorrect value obtained for y is substituted back into one of the equations to obtain a correct follow through value for x .

Mark awarded = 2 out of 3

(c) The correct value of 65° was the only answer allowed at this stage.

Mark awarded = 0 out of 1

Total mark awarded = 2 out of 5

Example candidate response – grade E

25 In quadrilateral $ABCD$

- angle $A = (2y + x)^\circ$
- angle $B = (3y + x)^\circ$
- angle $C = (2y + 10)^\circ$
- angle $D = (3x + 5)^\circ$

(a) By finding the sum of the angles in the quadrilateral, show that $7y + 5x = 345$.

$$\begin{aligned}
 &7y + 5x = 345 \\
 &= (2y + x) + (3y + x) + (2y + 10) + (3x + 5) = 360 \\
 &6y + 2x + 3x + 10 + 5 = 360 \\
 &6y + 5x + 15 = 360 \\
 &6y + 5x = 345 \quad [1]
 \end{aligned}$$

(b) Given that angle $A = 90^\circ$ then $2y + x = 90$.

Solve the simultaneous equations to find x and y .

$$\begin{aligned}
 &7y + 5x = 345 \\
 &2y + x = 90 \\
 &= 7y + 5x = 345 \\
 &\text{eq (ii)} \cdot 2y + x = 90 \rightarrow x = 90 - 2y \\
 &= 10y + 5x = 450 \\
 &7y + 5x = 345 \\
 &10y + 5x = 450 \\
 &\hline
 &-3y = -105 \\
 &y = 35 \\
 &y = 35 \text{ in eq (ii)} \\
 &2(35) + x = 90 \\
 &70 + x = 90 \\
 &x = 20 \\
 &\text{Answer } x = 20 \\
 &y = 35 \quad [3]
 \end{aligned}$$

(c) Find the size of the smallest angle in the quadrilateral.

$$\begin{aligned}
 &= (2y + x) = 345 \\
 &x = 345 \\
 &= 2y + x = 345 \\
 &2(35) + x = 345 \\
 &70 + x = 345 \\
 &x = 275 \\
 &\text{Answer } 69/14 \quad [1]
 \end{aligned}$$

Examiner comment – grade E

(a) There is no statement that the sum of the angles should be 360° .

Mark awarded = 0 out of 1

(b) y is correctly obtained by eliminating x using appropriate multiples of each equation. The subtraction used gave rise to two negative values which were correctly resolved. In attempting to evaluate x , a correct substitution is made. But the final step uses division instead of subtraction.

Mark awarded = 2 out of 3

(c) The candidate appears to be attempting to solve some more equations at this point.

Mark awarded = 0 out of 1

Total mark awarded = 2 out of 5

Paper 2

Question 1

Mark scheme

Question	Answers	Mark	Part marks
1 (a)	138 to 140	1	
(b)	D marked at intersection of correct arcs	2	<p>B1 for a correctly positioned D with one correct construction arc or no correct arcs Or, provided D to the west of AB</p> <p>B1 for D on one correct arc or radii 5 cm and 6 cm reversed with arcs Or, provided D to the east of AB</p> <p>B1 for D on intersection of two correct construction arcs</p>
(c)	103°	1	Tolerance $\pm 2^\circ$
(d) (i)	P and Q marked at intersection of perpendicular bisector and circle	3	<p>B1 for perpendicular bisector of AC minimum 3 cm long</p> <p>B1 for arcs radius 4.5 cm centre B, minimum 3 cm long cumulatively</p> <p>B1 for P and Q at correct positions</p>
(ii)	249°	1	Tolerance $\pm 2^\circ$

Example candidate response – grade A

- 1 The scale drawing shows three airfields, A , B and C , with B due north of A . The scale is 1 cm to 20 km.

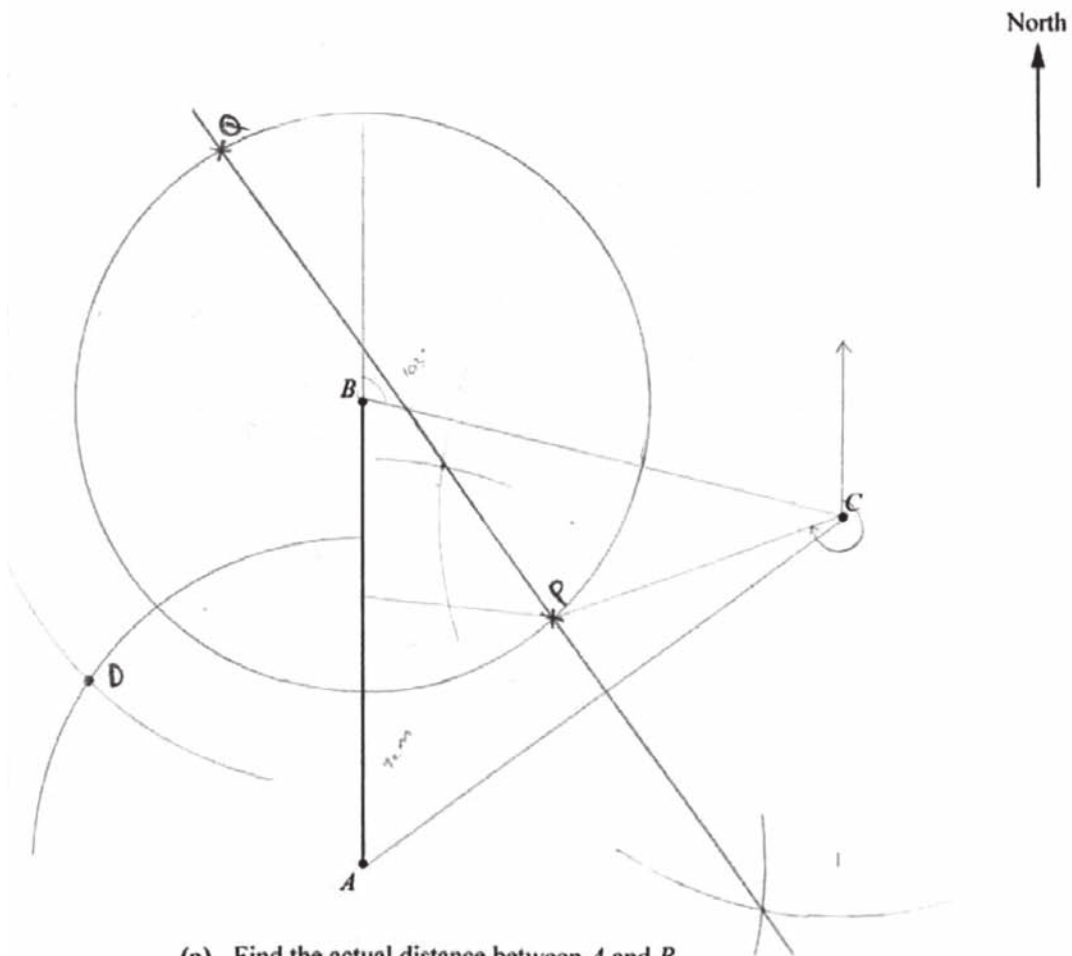

- (a) Find the actual distance between A and B .

Answer 140 km km [1]

$$1 \text{ cm} = 20 \text{ km}$$

$$7 \text{ cm} = x$$

$$7 \times 20 = 140$$

- (b) A beacon, D , is to the west of the line AB .
It is 100 km from A and 120 km from B .

Construct the position of D on the scale drawing. [2]

- (c) Measure the bearing of C from B .

Answer103°..... [1]

- (d) An aircraft is

- equidistant from A and C ,
- 90 km from B .

- (i) By constructing suitable loci, mark on the diagram the two possible positions, P and Q , of the aircraft. [3]

- (ii) Given that the aircraft is east of the line AB , find, by measuring, its bearing from C .

$$180 + 52 \\ = 232^\circ$$

Answer233°..... [1]

$$1 \text{ cm} = 20 \text{ km}$$

$$x = 100 \text{ km}$$

$$\frac{100}{20} = 5 \text{ cm from } A$$

$$\frac{120}{20} = 6 \text{ cm from } B$$

$$1 \text{ cm} = 20 \text{ km}$$

$$x = 90 \text{ km}$$

$$\frac{90}{20} = 4.5 \text{ cm}$$

Examiner comment – grade A

(a) Candidates at this ability level rarely have any difficulty with this type of question.

Mark awarded = 1 out of 1

(b) The candidate gave a clear and accurate answer. The arcs are easy to see and the intersection is clearly labelled.

Mark awarded = 2 out of 2

(c) An accurate answer showing that the candidate understands bearings.

Mark awarded = 1 out of 1

(d) (i) This is an excellent response. All the construction arcs are clearly shown and the points P and Q clearly marked. Good candidates sometimes lose marks in this sort of question by constructing one locus and then simply marking the required intersection points without drawing the second locus. This candidate has very clearly given both loci.

Mark awarded = 3 out of 3

(ii) A difficult part. Bearings in this quadrant are not generally well understood. This candidate did understand what was required but lost the mark when adding $52/53$ on to 180 , giving the bearing of the point A from C rather than that of P from C .

Mark awarded = 0 out of 1

Total mark awarded = 7 out of 8

Example candidate response – grade C

- 1 The scale drawing shows three airfields, A , B and C , with B due north of A . The scale is 1 cm to 20 km.

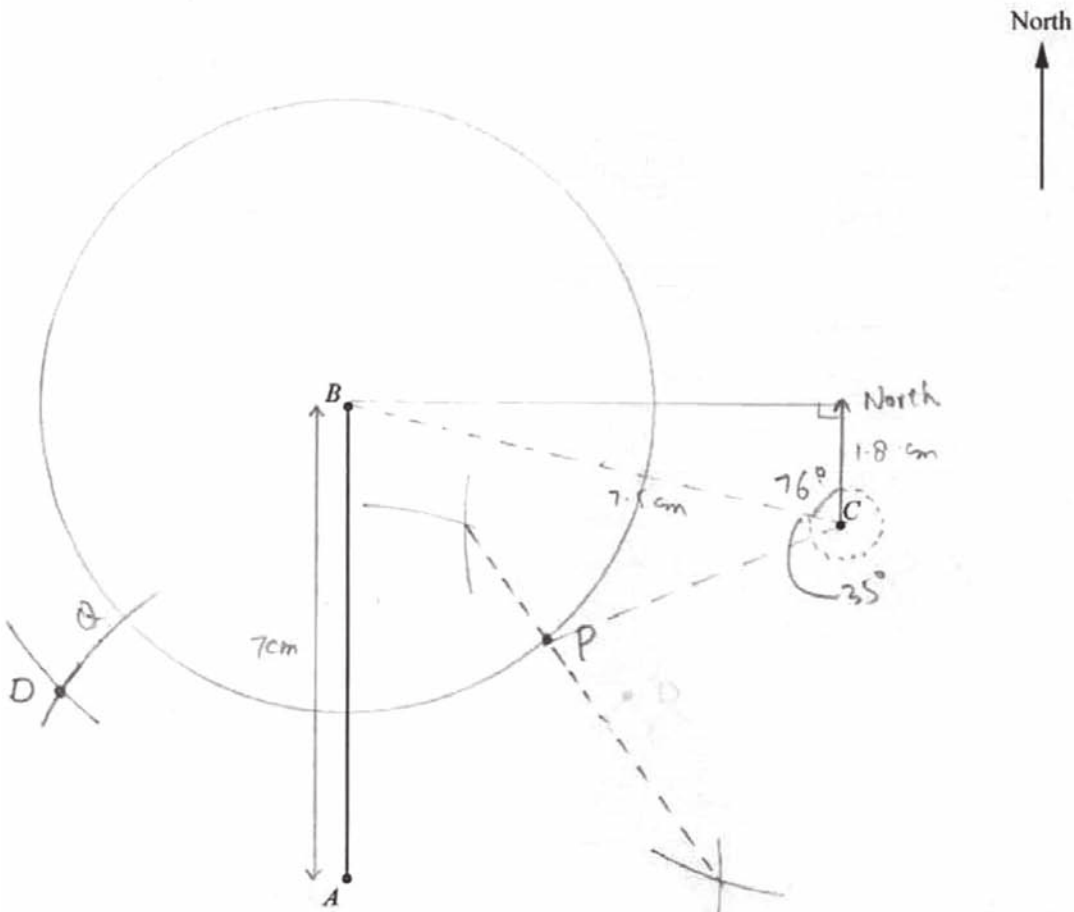

- (a) Find the actual distance between A and B .

$$\begin{aligned} 1 \text{ cm} &= 20 \text{ km} \\ 7 \text{ cm} &= x \\ x &= 7 \times 20 \end{aligned}$$

Answer 140 km [1]

- (b) A beacon, D , is to the west of the line AB .
It is 100 km from A and 120 km from B .

Construct the position of D on the scale drawing.

[2]

- (c) Measure the bearing of C from B .

$$\cos \theta = \frac{1.8}{7.5} \quad \theta = \cos^{-1} 0.24 = 76^\circ$$

$$= 360^\circ - 76^\circ \quad \text{Answer} \dots\dots\dots 284^\circ \quad [1]$$

- (d) An aircraft is

- equidistant from A and C ,
- 90 km from B .

- (i) By constructing suitable loci, mark on the diagram the two possible positions, P and Q , of the aircraft.

[3]

- (ii) Given that the aircraft is east of the line AB , find, by measuring, its bearing from C .

$$\left(\frac{360^\circ - 76^\circ}{2} \right)$$

$$\text{Answer} \dots\dots\dots 035^\circ \quad [1]$$

Examiner comment – grade C

- (a) The candidate has no difficulty here, showing the length of the line AB and the calculation to find the actual distance.

Mark awarded = 1 out of 1

- (b) Both marks are earned with clear arcs shown and the point D clearly labelled. This candidate avoided the frequently seen errors made at this level of either finding the point to the East of the line A instead of the West or reversing the 6cm and the 5cm.

Mark awarded = 2 out of 2

- (c) The candidate chose to ‘calculate’ rather than ‘measure’ the bearing. This could have given the right answer but the bearing given was that of B from C instead of C from B as the question required.

Mark awarded = 0 out of 1

- (d) (i) This is a good attempt. The candidate shows a good knowledge of loci, describing the full circle around B and drawing an accurate perpendicular bisector of AC . Unfortunately this line is not long enough and so although one point of intersection is found, the other is missed.

Mark awarded = 2 out of 3

- (ii) The angle BCE is measured here and given as the bearing.

Mark awarded = 0 out of 1

Total mark awarded = 5 out of 8

Example candidate response – grade E

- 1 The scale drawing shows three airfields, *A*, *B* and *C*, with *B* due north of *A*.
The scale is 1 cm to 20 km.

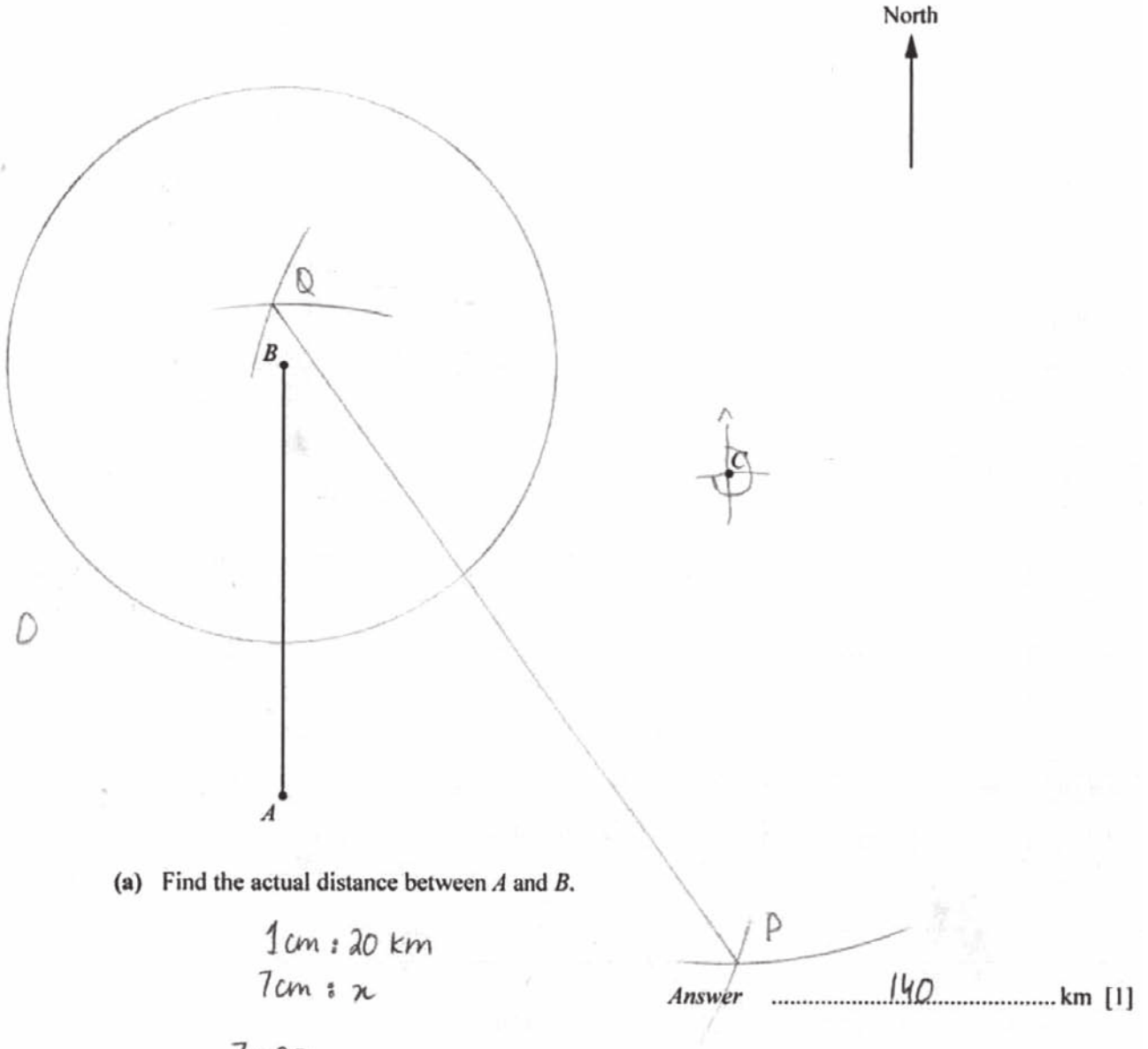

- (b) A beacon, D , is to the west of the line AB .
It is 100 km from A and 120 km from B .

Construct the position of D on the scale drawing.

[2]

- (c) Measure the bearing of C from B .

Answer 180° [1]

- (d) An aircraft is

- equidistant from A and C ,
- 90 km from B .

- (i) By constructing suitable loci, mark on the diagram the two possible positions, P and Q , of the aircraft. [3]

- (ii) Given that the aircraft is east of the line AB , find, by measuring, its bearing from C .

Answer 270° [1]

Examiner comment – grade E

- (a) A straightforward part, with the working shown and the correct answer given.

Mark awarded = 1 out of 1

- (b) The candidate tries to locate the point D without using any construction arcs, and only gives a rough indication of where the point should be. One mark could have been given if the point had been marked accurately.

Mark awarded = 0 out of 2

- (c) An answer of 180 suggests that the candidate has little idea of bearings. Many grade E candidates do have difficulty with this topic but quite a number did manage this fairly straightforward part.

Mark awarded = 0 out of 1

- (d) (i) A good understanding of loci is shown here with both the circle and the perpendicular bisector drawn accurately, earning the first two marks. The candidate does not realise, however, that the points of intersection of these loci are required, and places P and Q at two apparently random points on the bisector.

Mark awarded = 2 out of 3

- (ii) The answer here confirms that the candidate struggles with bearings. The 270 does not appear to have any relationship to the points P or Q .

Mark awarded = 0 out of 1

Total mark awarded = 3 out of 8

Question 2

Mark scheme

2	(a) (i) 97	1	
	(ii) $(c = \pm)\sqrt{\frac{4f + d}{6}}$	2	M1 for $4f = 6c^2 - d$ or better
	(b) $x \geq 2$ cao	2	B1 for final answer $\{+ \text{ or } -\} x * \{+ \text{ or } -\} 2$, where * can be wrong inequality or equals
	(c) $(3 + 5x)(3 - 5x)$ oe	1	Must be integers
	(d) $(8p - 3q)(x - 2y)$ oe seen isw	2	M1 for $x(8p - 3q)$ oe or $-2y(8p - 3q)$ oe Or $8p(x - 2y)$ oe or $-3q(x - 2y)$ oe

Example candidate response – grade A

2 (a) $f = \frac{6c^2 - d}{4}$

(i) Find f when $c = 8$ and $d = -4$.

Answer 97 [1]

(ii) Express c in terms of d and f .

$$f = \frac{6c^2 - d}{4}$$

$$\Rightarrow 4f = 6c^2 - d$$

$$\Rightarrow 6c^2 = 4f + d$$

$$\Rightarrow c^2 = \frac{4f + d}{6}$$

$$\Rightarrow c = \sqrt{\frac{4f + d}{6}}$$

Answer $\sqrt{\frac{4f + d}{6}}$ [2]

(b) Solve $17 - 5x \leq 2x + 3$.

$$17 - 5x \leq 2x + 3$$

$$= -5x - 2x \leq 3 - 17$$

$$= -7x \leq -14$$

$$= -x \leq -7$$

$$= x \geq 7$$

Answer $x \geq 7$ [2]

(c) Factorise $9 - 25x^2$.

Answer $(3 + 5x)(3 - 5x)$ [1]

(d) Factorise completely $8px + 6qy - 3qx - 16py$.

$$\begin{aligned}
 & 8px + 6qy - 3qx - 16py \\
 &= 8px - 3qx + 6qy - 16py \\
 &= x(8p - 3q) - 2y(8p - 3q) \\
 &= (x - 2y)(8p - 3q)
 \end{aligned}$$

Answer [2]

(e) Solve $5x^2 + 6x - 13 = 0$.

Give your answers correct to two decimal places.

$$\begin{aligned}
 & \frac{-b \pm \sqrt{b^2 - 4ac}}{2a} && a = 5 \\
 & && b = 6 \\
 & && c = -13 \\
 &= \frac{-6 \pm \sqrt{36 - 4(5)(-13)}}{2(5)} \\
 &= \frac{-6 \pm \sqrt{296}}{2(5)} \\
 &= \frac{-6 + \sqrt{296}}{10}, \quad \frac{-6 - \sqrt{296}}{10} \\
 &= -2.32 \quad \quad \quad = +1.20
 \end{aligned}$$

Answer $x = -2.32$ or $+1.20$ [4]

Examiner comment – grade A

- (a) (i) A straightforward start to the question and the candidate shows all the working.
(ii) Again all the steps are clearly shown in exemplary fashion.

Mark awarded = 3 out of 3

- (b) Although the candidate shows every step in the working and clearly fully understands how to deal with this type of inequality, the marks are lost with a slip at the last step when $14/7$ is given as 7.

Mark awarded = 0 out of 2

- (c) The 'difference of two squares' idea poses no problems to most candidates at this level, the only errors being slips.

Mark awarded = 1 out of 1

- (d) Again, a perfectly written out solution to this rather more difficult factorisation question.

Mark awarded = 2 out of 2

- (e) One mark is lost through a slip at the end of an otherwise perfect answer. The second solution is written down as 1.20 when the correct value is 1.12(0).

Mark awarded = 3 out of 3

Total mark awarded = 9 out of 12

Example candidate response – grade C

2 (a) $f = \frac{6c^2 - d}{4}$

(i) Find f when $c = 8$ and $d = -4$.

$$f = \frac{6(8)^2 - (-4)}{4}$$

$$= \frac{384 + 4}{4} = 97 //$$

Answer 97 [1]

(ii) Express c in terms of d and f .

$$f = \frac{6c^2 - d}{4}$$

$$f(4) = 6c^2 - d$$

$$f(4) + d = 6c^2$$

$$\sqrt{\frac{f(4) + d}{6}} = c$$

Answer $c = \sqrt{\frac{f(4) + d}{6}}$ [2]

(b) Solve $17 - 5x \leq 2x + 3$.

$$17 - 5x = 2x + 3$$

$$17 - 3 - 5x - 2x = 0$$

$$14 - 7x = 0$$

$$14 = 7x$$

$$x = \frac{14}{7}$$

$$x = 2 //$$

Answer $x = 2$ [2]

(c) Factorise $9 - 25x^2$.

$$3^2 - 5^2 x^2$$

$$3^2 - (5x)^2$$

Answer $(3 - 5x)^2$ [1]

(d) Factorise completely $8px + 6qy - 3qx - 16py$.

$$8px - 16py + 3qx + 6qy$$

$$4p(2x - 4y) = 3q(x + 2y) \quad \therefore (2x - 8y)^2 (4p - 3q)$$

$$(2x - 4y)(x + 2y)$$

$$2x^2 + 4xy - 4yx - 8y^2$$

$$(2x^2 - 8y^2)$$

$$(2x - 8y)^2$$

Answer $(2x - 8y)^2 (4p - 3q)$ [2]

(e) Solve $5x^2 + 6x - 13 = 0$.

Give your answers correct to two decimal places.

$$a = 5, b = 6, c = -13$$

$$x = \frac{-b \pm \sqrt{b^2 - 4ac}}{2a}$$

$$x = \frac{-6 \pm \sqrt{6^2 - 4(5)(-13)}}{2(5)}$$

$$x = \frac{-6 \pm \sqrt{296}}{10}$$

$$x = \frac{-6 \pm 17.2}{10}$$

$$x = \frac{-6 + 17.2}{10} \quad \text{or} \quad x = \frac{-6 - 17.2}{10}$$

$$x = 1.12 \quad \text{or} \quad x = -2.32$$

Answer $x = \dots\dots\dots 1.12 \dots\dots\dots$ or $\dots\dots\dots -2.32 \dots\dots\dots$ [4]

Examiner comments – grade C

- (a) (i) The candidate has no difficulty substituting the given values into the expression.
(ii) Again, a correct expression found with clear working shown.

This candidate has avoided the common error of getting as far as the last step and then suggesting that the square root covers only the numerator of the expression.

Mark awarded = 3 out of 3

- (b) The candidate has treated this as an equation to solve and has produced $x = 2$ as the answer to gain one mark. This is not an uncommon tactic, but candidates then usually try to give their final answer as an inequality.

Mark awarded = 1 out of 2

- (c) This is a fairly common wrong answer with the candidates recognising that the difference of two squares is involved but not knowing how to deal with it.

Mark awarded = 0 out of 1

- (d) The candidate has clearly got a good idea of what is involved here and has sorted out the two pairs, but unfortunately then makes two errors and so doesn't pick up either mark. With the first pair the factor $4p$ is taken out but the extra 2 forgotten and then the second pair produces a sign error. If the candidate had tried to multiply out the final expression the errors might well have been found and corrected.

Mark awarded = 0 out of 2

- (e) This is an excellently written out solution gaining full marks.

Mark awarded = 4 out of 4**Total mark awarded = 8 out of 12**

Example candidate response – grade E

2 (a) $f = \frac{6c^2 - d}{4}$

(i) Find f when $c = 8$ and $d = -4$.

$$f = \frac{6(8)^2 - (-4)}{4} = \frac{6(64) - (-4)}{4} \quad \text{Answer } \dots 97 \dots [1]$$

(ii) Express c in terms of d and f .

$$\begin{aligned} -97 &= \frac{6c^2 - (-4)}{4} & c &= 8.082 \\ 388 &= 6c^2 - (-4) \\ 392 &= 6c^2 \\ \sqrt{65.333} &= \sqrt{c^2} & \text{Answer } \dots 8.082 \dots [2] \end{aligned}$$

(b) Solve $17 - 5x \leq 2x + 3$.

$$\begin{aligned} 17 - 5x &\leq 2x + 3 \\ 17 - 3 &\leq 2x + 5x \\ 14 &\leq 7x \\ \frac{14}{7} &\leq x & \text{Answer } x \geq 2 \text{ or } 2 \leq x \dots [2] \end{aligned}$$

(c) Factorise $9 - 25x^2$.

$$(3 - 5x)^2 \quad \text{Answer } \dots (3 - 5x)^2 \dots [1]$$

(d) Factorise completely $8px + 6qy - 3qx - 16py$.

$$\begin{aligned} &P(8x + 6qy - 3qx - 16y) \\ &= (8x + 6qy - 3qx - 16y) \end{aligned}$$

Answer [2]

(e) Solve $5x^2 + 6x - 13 = 0$.

Give your answers correct to two decimal places.

$$x = \frac{-b \pm \sqrt{b^2 - 4ac}}{2a}$$

$$x = \frac{-6 \pm \sqrt{4(5)(-13)}}{2(5)}$$

$$x = \frac{\pm 6 \sqrt{-260}}{10}$$

$$x = \pm 6 \sqrt{-26}$$

$$6 \sqrt{-26}, -6 \sqrt{-26}$$

Answer $x = -30.594$ or 30.594 [4]

Examiner comment – grade E

(a) The candidate picks up the mark for part (i) but then makes the fairly common mistake of trying to substitute the first answer (97) back into the given expression and attempting to solve the resulting equation. In this case the candidate makes a further mistake and so fails to reach the answer 8, the original value of c . A number of candidates do not appear to be familiar with the phrase ‘in terms of’.

Mark awarded = 1 out of 3

(b) Very well answered – and the candidate even takes the final step of reversing the inequality to give x as the subject. Many candidates did not take this final step.

Mark awarded = 2 out of 2

(c) This is a very common error at this level.

Mark awarded = 0 out of 1

(d) Even very strong candidates can find this type of factorisation tricky and this candidate is unable to make a reasonable attempt.

Mark awarded = 0 out of 2

(e) The candidate recognises the need to use the quadratic formula but has only a hazy idea of what it is, and then makes a number of subsequent errors. The need to find the square root of a negative value is not a deterrent and the two answers are not corrected to two decimal places as required in the question.

Mark awarded = 0 out of 4

Total mark awarded = 3 out of 12

Question 3

Mark scheme

3	(a) (i)	533.9(0) to 534	2	M1 for $32 \times 5.20 + 0.15 \times 2450$
	(ii)	1760	3	M1 for $409.6 - 28 \times 5.20 [= 264]$ M1 for ' <i>their</i> 264' $\div 0.15$
	(b) (i)	3.75	2	SC1 for an answer of 28.75, 28.7, 28.8, 15, 3.7, 3.8 or 0.0375
	(ii)	402.5[0] or 403 or 402	2	M1 for $\frac{920}{(4 + 5 + 7)} \times 7$

Example candidate response – grade A

- 3 (a) Mariam works in a shop.
She earns \$5.20 per hour.
She also earns a bonus of 15% of the value of the items she sells in a week.

(i) In one week she works for 32 hours and sells items with a value of \$2450.

Calculate Mariam's total earnings for the week.

$$32 \text{ hrs} \times 5.20 = 166.4$$

$$2450 \times \frac{15}{100} = 367.5$$

Answer \$.....528.14..... [2]

(ii) In another week, Mariam worked for 28 hours and earned a total of \$409.60.

Calculate the value of the items she sold that week.

$$28 - 409.60$$

$$28 \times 5.20 = 145.6$$

$$x \times \frac{15}{100} = 264$$

$$409.60 - 145.6$$

$$= 264$$

Answer \$.....1760..... [3]

- (b) (i) Jack opens a bank account paying simple interest.
He pays in \$800 and leaves it in the account for 4 years.
At the end of 4 years he closes the account and receives \$920.

Calculate the percentage rate of simple interest paid per year.

$$920 = \frac{800R4}{100}$$

$$R = \frac{920(100)}{800(4)}$$

Answer28.75.....% [2]

- (ii) Jack uses some of the \$920 to pay for a holiday and a computer.
He saves the remainder.
The money is divided between the holiday, computer and savings in the ratio 4 : 5 : 7.

Calculate the amount he saves.

$$\frac{7}{16} \times 920$$

Answer \$.....402.5..... [2]

Examiner comment – grade A

- (a) (i) The candidate understands what is required but loses one of the two marks when 32×5.20 is written down as 160.64. This is probably a mistake in transferring the correct value 166.40 from the candidate's calculator.
- (ii) This rather harder part has been completed successfully and full marks earned.

Mark awarded = 4 out of 5

- (b) (i) The candidate makes the fairly common error of assuming that the interest is \$920 rather than $\$920 - \800 . The subsequent answer of \$28.75 is allowed one mark for correct working after the initial mistake.
- (ii) This part proved to be reasonably straightforward and this candidate had no difficulty getting to the correct answer.

Mark awarded = 3 out of 4

Total mark awarded = 7 out of 9

Example candidate response – grade C

- 3 (a) Mariam works in a shop.
She earns \$5.20 per hour.
She also earns a bonus of 15% of the value of the items she sells in a week.

- (i) In one week she works for 32 hours and sells items with a value of \$2450.

Calculate Mariam's total earnings for the week.

$$32 \times 5.20 = \$166.4$$

$$15\% \text{ of } 2450 \\ \frac{15}{100} \times 2450 = 367.5$$

$$166.4 + 367.5 \\ = 533.9$$

Answer \$.....533.9..... [2]

- (ii) In another week, Mariam worked for 28 hours and earned a total of \$409.60.

Calculate the value of the items she sold that week.

~~$$28 \times 5.20$$~~

$$(28 \times 5.20) + 15\% \text{ of } x = 409.60$$

$$145.6 + 15\% \text{ of } x = 409.60$$

$$409.60 - 145.6 = 264$$

$$\frac{264 \times 15}{100} = 39.6 \quad 15\% \text{ of } x = 264$$

Answer \$.....39.6..... [3]

- (b) (i) Jack opens a bank account paying simple interest.
He pays in \$800 and leaves it in the account for 4 years.
At the end of 4 years he closes the account and receives \$920.

PRT

Calculate the percentage rate of simple interest paid per year.

$$\frac{800 \times x \times 4}{100} = 920$$

$$3200x = 92000$$

$$x = \frac{92000}{3200} = 28.75$$

Answer28.75.....% [2]

- (ii) Jack uses some of the \$920 to pay for a holiday and a computer.
He saves the remainder.
The money is divided between the holiday, computer and savings in the ratio 4 : 5 : 7.

Calculate the amount he saves.

$$\frac{4}{16} \times x = 920$$

$$3680$$

$$3680 \rightarrow \text{total} \\ \frac{920}{16} \times 16 = 920 \\ 3680 - 920 \\ = 2760$$

Answer \$.....2760..... [2]

Examiner comment – grade C

- (a) (i) This part is well answered with all the working clearly shown.
(ii) The candidate has made a good attempt here, getting as far as '15% of $x = \$264$ ' but then being unable to work out how to find the value of x , and resorting to finding 15% of 264. Getting to 264 and not being able to complete was fairly common. Some left this as their answer, others multiplied by 1.15, as well as those who did the same as this candidate.

Mark awarded = 3 out of 5

- (b) (i) The candidate gains the one mark for finding the rate of interest if the interest had been \$920.
(ii) Most candidates at this level found this part to be relatively easy but this candidate misunderstood the question completely, assuming that the \$920 is the amount saved and then working out the imagined total.

Mark awarded = 1 out of 4

Total mark awarded = 4 out of 9

Example candidate response – grade E

- 3 (a) Mariam works in a shop.
She earns \$5.20 per hour.
She also earns a bonus of 15% of the value of the items she sells in a week.

- (i) In one week she works for 32 hours and sells items with a value of \$2450.

Calculate Mariam's total earnings for the week.

$$32 \times \$ 5.20 = \$ 166.4$$

$$15 \% \times 2450 = 367.5$$

$$2450 - 367.5 = 2082.5$$

$$\$ 2082.5 + \$ 166.4 = \$ 2248.9 \quad \text{Answer } \$ \dots\dots\dots 2248.9 \quad [2]$$

- (ii) In another week, Mariam worked for 28 hours and earned a total of \$409.60 .

Calculate the value of the items she sold that week.

$$28 \times \$ 5.20 = \$ 145.6$$

$$\$ 409.60 - \$ 145.6 = \$ 264$$

$$\text{Answer } \$ \dots\dots\dots \cancel{246} 264 \quad [3]$$

- (b) (i) Jack opens a bank account paying simple interest.
He pays in \$800 and leaves it in the account for 4 years.
At the end of 4 years he closes the account and receives \$920.

Calculate the percentage rate of simple interest paid per year.

$$\frac{120}{4} = 30\%$$

$$\text{Answer } \dots\dots\dots 30 \dots\dots\dots \% \quad [2]$$

- (ii) Jack uses some of the \$920 to pay for a holiday and a computer.
He saves the remainder.
The money is divided between the holiday, computer and savings in the ratio 4 : 5 : 7 .

Calculate the amount he saves. $\frac{7}{16} \times 920 = \$ 402.5$

$$\text{Answer } \$ \dots\dots\dots 402.5 \quad [2]$$

Examiner comment – grade E

- (a) (i) The candidate starts off correctly by finding the two individual amounts that make up the total earnings that the question requires. Unfortunately the subsequent working shows that the idea of hourly pay and bonus is not understood. Many other candidates also had difficulty with the idea and a number thought that it was necessary to add on a further \$2450.
- (ii) This candidate was one of many who got as far as \$264 and then stopped.

Mark awarded = 1 out of 5

- (b) (i) This candidate did recognise that the interest was \$120 but then simply divided by the time (four years).
- (ii) This part was well answered by the most concise method. Other candidates did not read the question carefully enough and gave all three values. A small number divided \$920 by 4, 5, and 7 to get the apportionments.

Mark awarded = 2 out of 4

Total mark awarded = 3 out of 9

Question 4

Mark scheme

4	(a) (i)	$\frac{1}{3}$	1	
	(ii)	$\frac{2}{3}$	1	
	(b) (i)	25 numbers completed correctly	1	
	(ii) (a)	$\frac{18}{30}$ oe isw	1	
	(b)	$\frac{8}{30}$ oe isw	1	

After 0+0 allow **B1** for 2/6 **and** 4/6
Or 0.33 **and** 0.66 or better

After 0+0+0 for **(b)**,
If all 36 used **B1** for 18/36 **and** 10/36
If 35 used, **B1** for 18/35 **and** 9/35

Example candidate response – grade A

- 4 A bag contains six identical balls numbered 2, 3, 4, 5, 6 and 7. Total
6

(a) A ball is taken from the bag at random.

Find, as a fraction in its lowest terms, the probability that the number on the ball is

(i) a multiple of 3,

$$\frac{2}{6} = \frac{1}{3}$$

Answer $\frac{1}{3}$ [1]

(ii) prime.

$$\frac{4}{6} = \frac{2}{3}$$

Answer $\frac{2}{3}$ [1]

(b) All six balls are replaced in the bag.

Two balls are taken from the bag, one after the other, without replacement.

The numbers on the two balls are added together.

(i) Complete this possibility diagram to show all the outcomes.

+	2	3	4	5	6	7
2		5	6	7	8	9
3	5	6	7	8	9	10
4	6	7	8	9	10	11
5	7	8	9	10	11	12
6	8	9	10	11	12	13
7	9	10	11	12	13	14

[1]

(ii) Find the probability that the sum of the numbers is

(a) odd,

$$\frac{18}{30} = \frac{9}{15} = \frac{3}{5}$$

Answer $\frac{3}{5}$ [1]

(b) less than 8.

$$\frac{8}{30} = \frac{4}{15}$$

Answer $\frac{4}{15}$ [1]

Examiner comment – grade A

- (a) Two very straightforward probability questions which most candidates were able to complete successfully. When marks were lost it was usually because the answers were not given in their lowest terms. This candidate had no difficulty, showing the working stages (2/6 and 4/6) before the corrected values.

Mark awarded = 2 out of 2

- (b) This appeared to be another straightforward question, but many candidates had difficulty understanding what the question meant. In particular many either ignored or did not know how to respond to the phrase 'without replacement'. This candidate did not make clear what was intended in the possibility diagram, and lost the first mark but then went on and showed that the idea of the question had been understood by giving both answers in part (ii) correctly in their simplified form.

Mark awarded = 2 out of 3

Total mark awarded = 4 out of 5

Example candidate response – grade C

4 A bag contains six identical balls numbered 2, 3, 4, 5, 6 and 7.

(a) A ball is taken from the bag at random.

Find, as a fraction in its lowest terms, the probability that the number on the ball is

(i) a multiple of 3,

$$P(E) = \left(\frac{\cancel{2}1}{\cancel{6}3} \right) = \frac{1}{3}$$

Answer $\frac{1}{3}$ [1]

(ii) prime.

$$P(\text{Prime number}) = \left(\frac{\cancel{4}2}{\cancel{6}3} \right) = \frac{2}{3}$$

Answer $\frac{2}{3}$ [1]

(b) All six balls are replaced in the bag.

Two balls are taken from the bag, one after the other, without replacement.

The numbers on the two balls are added together.

(i) Complete this possibility diagram to show all the outcomes.

#	2	3	4	5	6	7
2		5	6	7	8	9
3	5	6	7	8	9	10
4	6	7	8	9	10	11
5	7	8	9	10	11	12
6	8	9	10	11	12	13
7	9	10	11	12	13	14

[1]

(ii) Find the probability that the sum of the numbers is

$$P(\text{odd sum}) = \left(\frac{18}{35} \right)$$

Answer $\frac{18}{35}$ [1]

$$P(\text{less than 8}) = \left(\frac{9}{35} \right)$$

Answer $\frac{9}{35}$ [1]

Examiner comment – grade C

(a) Both answers are given correctly and in their simplified form.

Mark awarded = 2 out of 2

(b) (i) The candidate makes the common mistake with the leading diagonal of ignoring the `without replacement` instruction and completing all the values in the grid apart from the one already shaded in the question.

(ii) Although both answers are wrong the candidate has been allowed one mark for the answers $15/35$ and $9/35$, i.e. for finding the correct probabilities with the figures which were given in the grid.

Mark awarded = 1 out of 3

Total mark awarded = 3 out of 5

Example candidate response – grade E

4 A bag contains six identical balls numbered ^{1 2 3 4 5 6} 2, 3, 4, 5, 6 and 7.

(a) A ball is taken from the bag at random.

Find, as a fraction in its lowest terms, the probability that the number on the ball is

(i) a multiple of 3,

3, 6

Answer $\frac{2}{6}$ [1]

(ii) prime.

2, 3, 5, 7

Answer $\frac{4}{6}$ [1]

(b) All six balls are replaced in the bag.

Two balls are taken from the bag, one after the other, without replacement. The numbers on the two balls are added together.

(i) Complete this possibility diagram to show all the outcomes.

+	2	3	4	5	6	7
2		5	6	7	8	9
3	5	6	7	8	9	10
4	6	7	8	9	10	11
5	7	8	9	10	11	12
6	8	9	10	11	12	13
7	9	10	11	12	13	14

[1]

(ii) Find the probability that the sum of the numbers is

(a) odd,

Answer $\frac{4}{14}$ [1]

(b) less than 8.

Answer $\frac{3}{14}$ [1]

Examiner comment – grade E

(a) The candidate found both probabilities correctly, but didn't give the fractions 'in their lowest terms' as the question required and so was awarded just one of the two available marks.

Mark awarded = 1 out of 2

(b) The candidate made the usual error of filling in the leading diagonal, but it is then difficult to see where the two answers of $4/14$ and $3/14$ come from, i.e. they do not follow through from the numbers in the grid.

Mark awarded = 0 out of 3

Total mark awarded = 1 out of 5

Question 5

Mark scheme

5	(a)	78.1 to 78.13	2	M1 for $\cos 35 = \frac{64}{AB}$ or better
	(b)	127.9 to 128	3	M1 for $64^2 + 80^2 + or - (2) \times 64 \times 80 \cos 125$ M1 for $AD^2 = 64^2 + 80^2 - 2 \times 64 \times 80 \cos 125$
	(c)	24.1 to 24.2°	3	M1 for $\frac{\sin ADC}{64} = \frac{\sin 125}{their128}$ oe M1 for $\sin ADC = \frac{64 \times \sin 125}{their128}$
	(d)	2900	2	M1 for $0.5 \times (80 + 65) \times 40$

Example candidate response – grade A

5

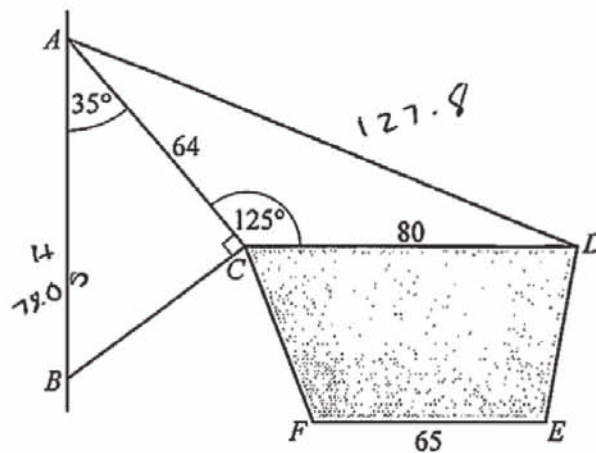

The diagram shows a framework $ABCD$ supporting a shop sign. The framework is fixed to a vertical wall AB with CD horizontal. $AC = 64$ cm and $CD = 80$ cm. $\hat{BAC} = 35^\circ$, $\hat{BCA} = 90^\circ$ and $\hat{ACD} = 125^\circ$.

TC-S
OAG
AHIT

(a) Calculate AB .

$$\cos 35^\circ = \frac{64}{h}$$

$$h = \frac{64}{\cos 35}$$

$$h = \frac{64}{0.82}$$

Answer 78.05 cm [2]

(b) Calculate AD .

$$\frac{a}{\sin 125}$$

$$a^2 = b^2 + c^2 - 2(b)(c) \cos A$$

$$a^2 = 64^2 + 80^2 - 2(64)(80) \cos 125^\circ$$

$$a^2 = 10496 - 2(64)(80)(-0.57)$$

$$a^2 = 10496 + 5836.8$$

$$a^2 = 16332.8$$

$$a = 127.8$$

Answer 127.8 cm [3]

(c) Calculate \hat{ADC} .

$$\frac{127.8}{\sin 125^\circ} = \frac{64}{\sin ADC}$$

$$\sin ADC (127.8) = 62.43$$

$$\sin ADC = 0.411$$

$$\hat{ADC} = 24.3^\circ$$

Answer 24.3 [3]

- (d) On the sign $CDEF$, FE is parallel to CD and is 40 cm below it.
 $FE = 65$ cm.

Calculate the area of the sign $CDEF$.

$$\frac{1}{2} \times 40 \times (80 + 65)$$

$$\frac{1}{2} \times 40 \times (145) = 2900 \text{ cm}^2$$

Answer2900..... cm² [2]

Examiner comment – grade A

- (a) Most candidates tackled this question well and appeared to be well practised in trigonometry methods. Nevertheless many marks were lost through premature approximation and relatively few candidates seemed to ask themselves whether or not their answers were reasonable. Even good candidates need to be reminded that when an answer is to be given correct to three significant figures then all the working should be to at least four figures. This candidate readily gets to the correct expression $AB = 64 / \cos 35$ but then uses 0.82 for $\cos 35$ (from 0.81915...) and loses the accuracy mark.

Mark awarded = 1 out of 2

- (b) A similar error here. The cosine rule is stated and used correctly, but even though elsewhere numbers are written down to 6 figures, $\sin 125$ is approximated to -0.57 and another accuracy mark is lost.

Mark awarded = 2 out of 3

- (c) A further minor error, 0.411 used instead of 0.4102, produces an answer for angle ADC which is slightly outside the acceptable range and a third mark is lost.

Mark awarded = 2 out of 3

- (d) The candidate has no problem with this straightforward calculation of the area of a trapezium and earns both marks.

Mark awarded = 2 out of 2

Total mark awarded = 7 out of 10

Example candidate response – grade C

5

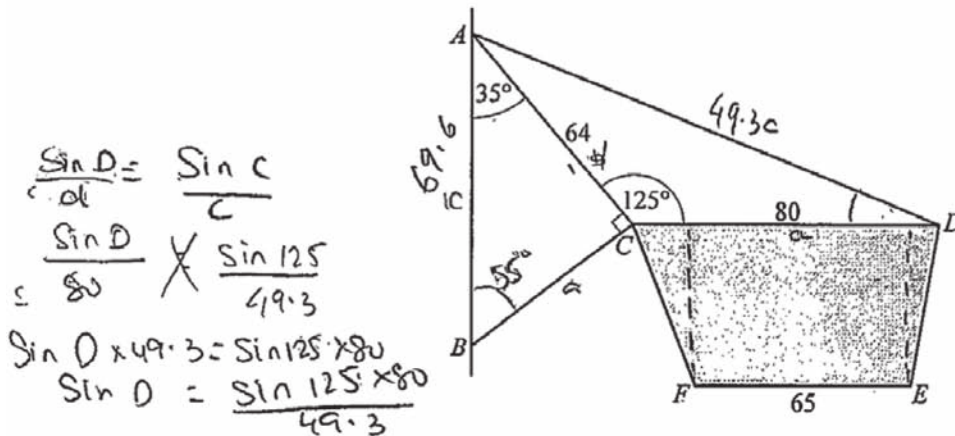

The diagram shows a framework $ABCD$ supporting a shop sign. The framework is fixed to a vertical wall AB with CD horizontal. $AC = 64$ cm and $CD = 80$ cm. $BAC = 35^\circ$, $BCA = 90^\circ$ and $ACD = 125^\circ$.

(a) Calculate AB .

$$\hat{A}BC = 180^\circ - (90 + 35) = 55^\circ$$

$$a = \frac{64 \times \sin 35^\circ}{\sin 55^\circ}$$

$$\frac{a}{\sin A} = \frac{b}{\sin B}$$

$$\frac{a}{\sin 35^\circ} = \frac{64}{\sin 55^\circ}$$

$$a \times \sin 55^\circ = 64 \times \sin 35^\circ$$

$$= 27.4$$

$$AB^2 = 27.4^2 + 64^2$$

$$= 750.76 + 4096$$

Answer 69.6 cm [2]

$$AB^2 = 4846.76$$

$$AB = \sqrt{4846.76}$$

$$= 69.6$$

(b) Calculate AD .

$$c^2 = a^2 + d^2 - 2ad \cos C$$

$$= 80^2 + 64^2 - 2(80)(64) \cos 125$$

$$= 6400 + 4096 - 10240 \cos 125$$

$$= 2429$$

$$c = \sqrt{2429}$$

$$= 49.3$$

Answer 49.3 cm [3]

(c) Calculate $\hat{A}DC$.

$$\cos D = \frac{80^2 + 49.3^2 - 64^2}{2(80)(49.3)}$$

$$= 0.60$$

$$\therefore D = \cos^{-1}(0.60)$$

$$D = 0.93$$

Answer 0.93 [3]

- (d) On the sign $CDEF$, FE is parallel to CD and is 40 cm below it.
 $FE = 65$ cm.

Calculate the area of the sign $CDEF$.

$$\begin{aligned} \text{area} &= 80 \times 65 = 5200 \\ &= 5200 \end{aligned}$$

Answer5200..... cm² [2]

Examiner comment – grade C

- (a) The candidate uses a correct but long method, attempting to find AC by using the sine rule and then AB through Pythagoras's theorem. Unfortunately a mistake is made in the evaluation of AC .

Mark awarded = 1 out of 2

- (b) The substitution into the cosine rule is carried out correctly, but again an error is made in the arithmetic. A candidate at this level might well have realised that an answer of 49.3 was not possible in the given triangle.

Mark awarded = 2 out of 3

- (c) The candidate tried to find the angle in two different ways, one using the sine rule and the second using the cosine rule. In both cases, however, errors were made.

The sine rule showed some confusion between the angles at A and D , and the cosine rule method was spoiled by poor arithmetic.

Mark awarded = 2 out of 3

- (d) An unusual error here as the candidate tries to find the area of the trapezium by multiplying the two parallel sides together.

Mark awarded = 0 out of 2

Total mark awarded = 5 out of 10

Example candidate response – grade E

5

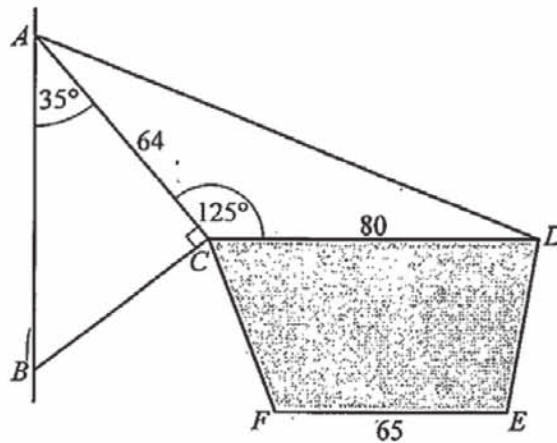

The diagram shows a framework $ABCD$ supporting a shop sign. The framework is fixed to a vertical wall AB with CD horizontal. $AC = 64$ cm and $CD = 80$ cm. $\hat{BAC} = 35^\circ$, $\hat{BCA} = 90^\circ$ and $\hat{ACD} = 125^\circ$.

(a) Calculate AB .

$$\tan 35^\circ = \frac{AB}{64}$$

$$\tan 35 \times 64 = AB$$

Answer 44.8 cm [2]

(b) Calculate AD .

$$\text{Cosine Rule} = a^2 = b^2 + c^2 - 2bc \cos A$$

$$a^2 = 64^2 + 80^2 - 2(64)(80) \cos(125)$$

$$a^2 = 4096 + 6400 - 10240 \cos(125)$$

$$a^2 = 256 \cos(125)$$

$$a^2 = 146.8$$

$$\sqrt{a^2} = \sqrt{146.8}$$

Answer 12.11 cm [3]

(c) Calculate \hat{ADC} .

$$\text{Sine Rule}$$

$$\frac{\sin A}{80} = \frac{\sin D}{64}$$

$$\frac{\sin 125^\circ}{80} = \frac{\sin D}{64}$$

$$\sin D = \frac{\sin 125^\circ \times 64}{80}$$

$$\sin D = 0.65$$

$$\sin^{-1}(0.65)$$

Answer 40.5 [3]

- (d) On the sign $CDEF$, FE is parallel to CD and is 40 cm below it.
 $FE = 65$ cm.

Calculate the area of the sign $CDEF$.

$$\frac{1}{2} (CD + FE) h$$

$$\frac{1}{2} (80 + 65) 40$$

Answer 2900 cm² [2]

Examiner comment – grade E

- (a) Most errors in this part tended to come after the correct initial trigonometric statement has been made. Here the candidate has used a wrong ratio.

Mark awarded = 0 out of 2

- (b) The correct statement of the cosine rule has been given and the numerical values substituted into the formula correctly, but the candidate then makes the mistake (not uncommon) of calculating the value of $4096 + 6400 - 10240$ and then multiplying this by $\cos 125$. The answer of 12 should have alerted the candidate that something was wrong.

Mark awarded = 2 out of 3

- (c) The candidate realises that the sine rule should be used but confuses the sides and angles. This was the best method to use here although some candidates successfully used the cosine rule again.

Mark awarded = 0 out of 3

- (d) The candidate was clearly familiar with the formula for the area of a trapezium and gained full marks for this part. Other candidates at this level treated it as a rectangle and simply found 40×65 or 40×80 .

Mark awarded = 2 out of 2

Total mark awarded = 4 out of 10

Question 6

Mark scheme

6	(a)	$23 - 6n$ cao	2	B1 for $-6n$ soi
	(b) (i)	4, 10, 18, 28	2	B1 for 3 correct terms seen
	(ii)	3 and 24	4	M1 for $\frac{n^2 + 3n}{5n - 12} = 6$ or better M1 for $n^2 - 27n + 72 = 0$ B1 for either 3 or 24

Example candidate response – grade A

- 6 (a) The first five terms of a sequence are 17, 11, 5, -1, -7.

Find, in terms of n , an expression for the n th term of this sequence:

$$\begin{aligned} & \cancel{17} - (2-1) \times 6 \\ & \cancel{17} - 6 \\ & = 11 \end{aligned}$$

$$\begin{aligned} & 17 - (n-1) \times 6 \\ & 17 - 6n + 6 \\ & 11 - 6n \end{aligned}$$

Answer $\dots\dots\dots 11-6n \dots\dots\dots$ [2]

- (b) The n th term, S_n , of a different sequence is found using the formula $S_n = n^2 + 3n$.

- (i) Work out the first four terms of this sequence.

$$\begin{aligned} S_n &= (4)^2 + 3(4) & 9 + 3(3) \\ &= 16 + 12 & = 18 \\ &= 28 \end{aligned}$$

$$\begin{aligned} & 1^2 + 3(1) \\ & 1 + 3 = 4 \end{aligned}$$

$$\begin{aligned} & 2^2 + 3(2) \\ & 4 + 6 = 10 \end{aligned}$$

Answer $\dots\dots\dots 4, \dots\dots\dots 10, \dots\dots\dots 18, \dots\dots\dots 28 \dots\dots\dots$ [2]

- (ii) The n th term, T_n , of another sequence is found using the formula $T_n = 5n - 12$.

There are two values of n for which $\frac{S_n}{T_n} = 6$.

Form and solve an equation in n to find these two values.

$$\frac{n^2 + 3n}{5n - 12} = 6$$

$$n^2 + 3n = 6(5n - 12)$$

$$n^2 + 3n = 30n - 72$$

$$n^2 + 3n - 30n + 72 = 0$$

$$n^2 - 27n + 72 = 0$$

$$n = \frac{+27 \pm \sqrt{(-27)^2 - 4(1)(72)}}{2(1)}$$

$$n = \frac{+27 \pm \sqrt{729 - 288}}{2}$$

$$n = \frac{27 \pm \sqrt{441}}{2}$$

$$n = \frac{27 \pm 21}{2}$$

$$\frac{6}{2} \text{ or } \frac{48}{2}$$

$$3 \text{ or } 24$$

Answer $n = \dots\dots\dots 3 \dots\dots\dots$ and $\dots\dots\dots 24 \dots\dots\dots$ [4]

Examiner comment – grade A

- (a) Many candidates struggled with this question, often because the sequence was decreasing, but this candidate clearly understood what was required, and used the expression $a + (n - 1)d$ to get to the correct $17 - (n - 1)6$. Unfortunately the candidate then multiplied out incorrectly to give an answer of $11 - 6n$. The $-6n$ earned one mark but the second was lost. Candidates should realise that it is always easy to check this sort of question by substituting a value for n (say $n = 1$). At this ability level it is very likely that the candidate would have been able to find the error and correct it.

Mark awarded = 1 out of 2

- (b) (i) All the working is shown and the correct values given.
(ii) The candidate has understood what the question required, has successfully found the two values and earned full marks. The candidate might have realised that since the two values must be integers the quadratic equation must factorise. As it was the quadratic formula was used and although the first line suggests an error might develop with the fraction line stopping short this is corrected in the next line.

Mark awarded = 6 out of 6

Total mark awarded = 7 out of 8

Example candidate response – grade C

- 6 (a) The first five terms of a sequence are $17, 11, 5, -1, -7$.

Find, in terms of n , an expression for the n th term of this sequence.

$$a + (n-1)d$$

$$17 + (n-1)6$$

Answer $n - 6$ [2]

- (b) The n th term, S_n , of a different sequence is found using the formula $S_n = n^2 + 3n$.

- (i) Work out the first four terms of this sequence.

$$* 1^2 + 3(1) \quad * 3^2 + 3(3) \quad 40$$

$$* 2^2 + 3(2) \quad * 4^2 + 3(4)$$

Answer 4 , 10 , 18 , 28 [2]

- (ii) The n th term, T_n , of another sequence is found using the formula $T_n = 5n - 12$.

There are two values of n for which $\frac{S_n}{T_n} = 6$.

Form and solve an equation in n to find these two values.

$$a + (n-1)d + \frac{(n+1)(n-2) \times d}{2} \quad \frac{18}{3}$$

$$5(6) - 12 = 18$$

$$\frac{n^2 + 3n}{5n - 12} = \frac{3^2 + 3(3)}{5(3) - 12}$$

Answer $n =$ 18 and 3 [4]

Examiner comment – grade C

- (a) The candidate tries to use the formula for the n th term of an AP, $a + (n-1)d$, but doesn't realise that the d should be negative. This attempt is then ignored and the (fairly common) wrong answer $n - 6$ given, the candidate perhaps recognising that -6 should be involved somehow.

Mark awarded = 0 out of 2

- (b) (i) All four terms were given correctly.
(ii) After an initial abortive attempt, the candidate used 'trial and error' to find the required terms. This is successful with the first term (3) but not with the second term, not surprising with the value being 24. Many candidates earned one mark in this way.

Mark awarded = 3 out of 6

Total mark awarded = 3 out of 8

Example candidate response – grade E

- 6 (a) The first five terms of a sequence are 17, 11, 5, -1, -7.

Find, in terms of n , an expression for the n th term of this sequence.

$$n - 6$$

Answer $n - 6$ [2]

- (b) The n th term, S_n , of a different sequence is found using the formula $S_n = n^2 + 3n$.

- (i) Work out the first four terms of this sequence.

$$S_n = n^2 + 3(2)$$

Answer 10, 18, 28, 40 [2]

- (ii) The n th term, T_n , of another sequence is found using the formula $T_n = 5n - 12$.

There are two values of n for which $\frac{S_n}{T_n} = 6$.

Form and solve an equation in n to find these two values.

$$\begin{aligned} \frac{n^2 + 3n}{5n - 12} &= 6 \\ n^2 + 3n &= 30n - 72 \\ n^2 + 3n - 30n &= -72 \\ n(n + 3) &= 2(15n - 36) = 3(10n - 24) \\ n(n + 3) &= 0 \\ \sqrt{n^2} &= \sqrt{3} \end{aligned}$$

$$\begin{aligned} 3(10n - 24) & \\ 30n - 24 &= 0 \\ n &= 24/30 \end{aligned}$$

Answer $n =$ 1.7 and 0.8 [4]

Examiner comment – grade E

(a) The candidate appears to have realised that, as the terms are reducing by 6, -6 should be involved in the answer but is not able to make any further progress. A simple check would have indicated the error and might have given a hint as to the correct steps necessary.

Mark awarded = 0 out of 2

- (b) (i) The candidate clearly knows what is needed here but unfortunately decides to start with $n = 2$ rather than $n = 1$, and loses one of the two marks available.
- (ii) The candidate successfully writes down the initial equation, and multiplies through to get rid of the fraction. One mark is given at this point but the candidate is not able to collect the terms to get the quadratic into the form to make further progress. Many candidates found this part difficult and even those who were able to get to the normal quadratic form often failed to realise that it factorised and were then unable to use the quadratic formula successfully.

Mark awarded = 2 out of 6

Total mark awarded = 2 out of 8

Question 7

Mark scheme

7	(a) (i)	9600 cao	2	M1 for $\frac{360}{60} \times 1600$ oe
	(ii)	$\frac{11}{60}$ cao	1	
	(iii)	1440 cao	2	M1 for $\frac{(144 - 90)}{360} \times \text{their} 9600$ oe
	(b) (i)	40.1	3	M1 for $12 \times 17.5 + 36 \times 25 + 45 \times 35 + 33 \times 50 + 24 \times 70$ M1 for division by <i>their</i> $(12 + 36 + \dots + 24)$
	(ii)	Correct histogram	3	B1 for 5 bars correct width and position B1 for at least 3 correct heights $k \times (2.4, 3.6, 4.5, 1.65, 1.2)$ B1 for 5 correct heights
	(iii)	38 or 39 or 40 or 41	1	

Example candidate response – grade A

7 (a) The pie chart summarises the results of a local election.

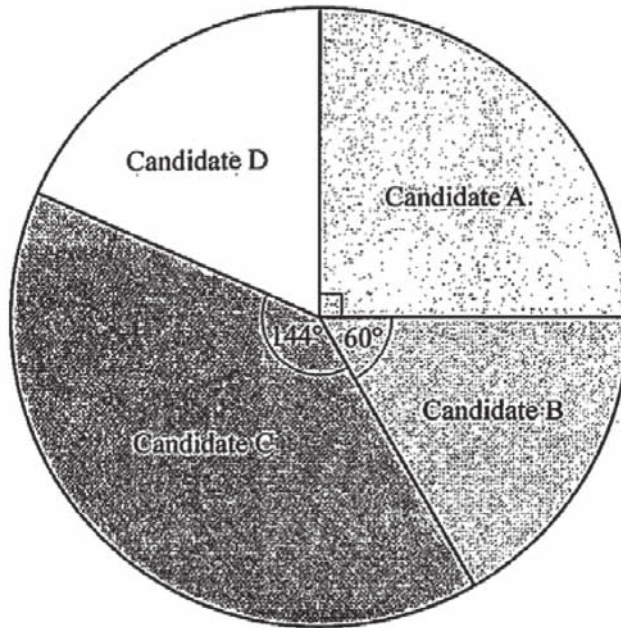

(i) Candidate B received 1600 votes.

Work out the total number of people who voted in the election.

$$\frac{60}{360} \times n = 1600 \quad \left| \quad n = 9600 \right.$$

$$60n = 576000$$

$$n = \frac{576000}{60}$$

Answer 9600 [2]

(ii) What fraction of the vote did candidate D receive?
Give your answer in its lowest terms.

$$90 + 60 + 144 = 294$$

$$360 - 294 = 66$$

$$\frac{66}{360} \times 9600 = \frac{633600}{360}$$

Answer $\frac{633600}{360} = 1760$ [1]

(iii) How many more votes than candidate A did candidate C receive?

candidate A = $\frac{90}{360} \times 9600 = 2400$

C = $\frac{144}{360} \times 9600 = 3840$

Answer 1440 [2]

$$3840 - 2400 = 1440$$

(b) The table summarises the ages of the members of a film club.

Age (a years)	$15 \leq a < 20$	$20 \leq a < 30$	$30 \leq a < 40$	$40 \leq a < 60$	$60 \leq a < 80$	= 150
Frequency	12	36	45	33	24	

Handwritten notes above the table: 2.4, 3.6, 4.5, 1.65, 1.2.

(i) Calculate an estimate of the mean age of the members.

$$\frac{15+20}{2} = 17.5, \quad \frac{20+30}{2} = 25, \quad \frac{30+40}{2} = 35, \quad \frac{40+60}{2} = 50, \quad \frac{60+80}{2} = 70$$

$$\frac{\sum fu}{\sum f} = \frac{17.5 \times 12 + 25 \times 36 + 35 \times 45 + 50 \times 33 + 70 \times 24}{150} = \frac{6015}{150} = 40.1$$

Answer 40.1 [3]

(ii) On the grid below, draw a histogram to represent this data.

Handwritten notes: frequency class intervals

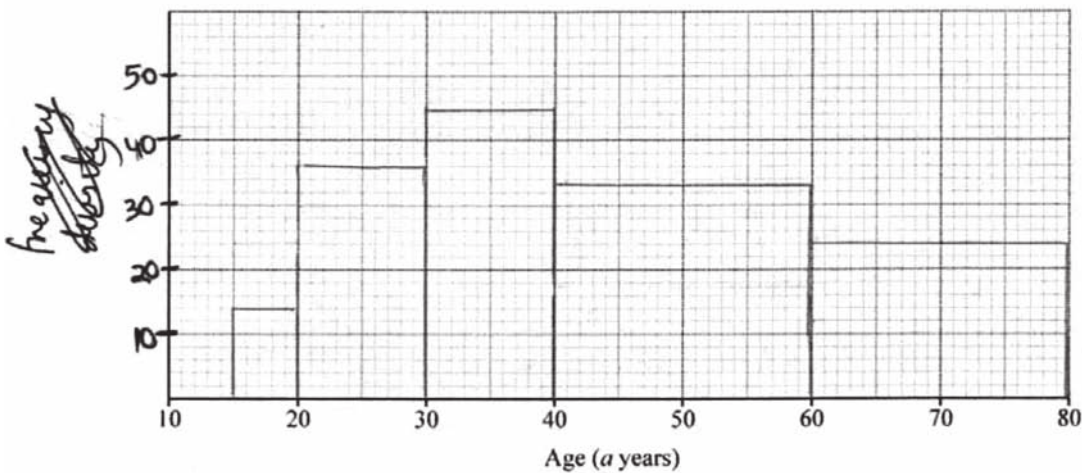

Handwritten notes on the right side of the grid: 12, 36, 45, 33, 24

[3]

(iii) Find an estimate for the number of members of the film club who are over 50.

$$1.65 = \frac{x}{10} \Rightarrow 16.5 \quad | \quad 24 + 16 = 40$$

$$60 \leq a < 80 \quad 24$$

Answer 40 [1]

Examiner comment – grade A

- (a) (i) A clear and accurate method was used although it would have been easier if the candidate had realised that $60/360$ simplified to $1/6$.
- (ii) The candidate found the angle for Candidate D and then the number of votes but forgot to go on to find the related fraction. The correct fraction ($66/360$) had appeared in the working, even though it still needed simplifying. This was in fact, a fairly common error with 1760 often appearing as the answer.
- (iii) The candidate might have realised that they could have found the difference between the two angles first and then gone straight to the answer. In all three parts the arithmetic was a bit laboured for a good A grade candidate.

Mark awarded = 4 out of 5

- (b) (i) A very clear well written answer.
- (ii) A very common error, even with strong candidates, plotting the actual frequencies rather than the frequency densities. This candidate was clearly familiar with histograms, initially writing 'frequency density' on the vertical axis and actually calculating these values. Unfortunately these were then ignored and frequencies plotted.
- (iii) A very good answer with the candidate finding half of the frequency $40 - 60$ adding 24 and then realising that the number of members should be an integer.

Mark awarded = 5 out of 7

Total mark awarded = 9 out of 12

Example candidate response – grade C

- 7 (a) The pie chart summarises the results of a local election.

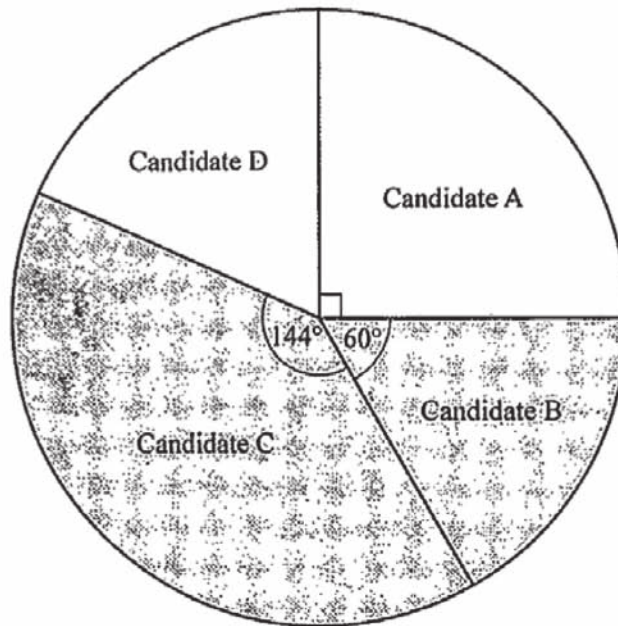

- (i) Candidate B received 1600 votes.

Work out the total number of people who voted in the election.

Answer 36000 [2]

- (ii) What fraction of the vote did candidate D receive?
Give your answer in its lowest terms.

$$= \frac{66}{360} = \frac{11}{60}$$

Answer $\frac{11}{60}$ [1]

- (iii) How many more votes than candidate A did candidate C receive?

$$= 144 - 90$$

Answer 54 [2]

(b) The table summarises the ages of the members of a film club.

Age (a years)	$15 \leq a < 20$	$20 \leq a < 30$	$30 \leq a < 40$	$40 \leq a < 60$	$60 \leq a < 80$
Frequency	12	36	45	33	24

(i) Calculate an estimate of the mean age of the members.

Age	Mid value (x)	frequency (f)	$f(x)$
$15 \leq a < 20$	17.5	12	210
$20 \leq a < 30$	25	36	900
$30 \leq a < 40$	35	45	1575
$40 \leq a < 60$	50	33	1650
$60 \leq a < 80$	70	24	1680
Total	197.5	150	6015

$Mean = \frac{f(x)}{f}$
 $= \frac{6015}{150}$
 $= 40.1$

Answer 40.1 [3]

(ii) On the grid below, draw a histogram to represent this data.

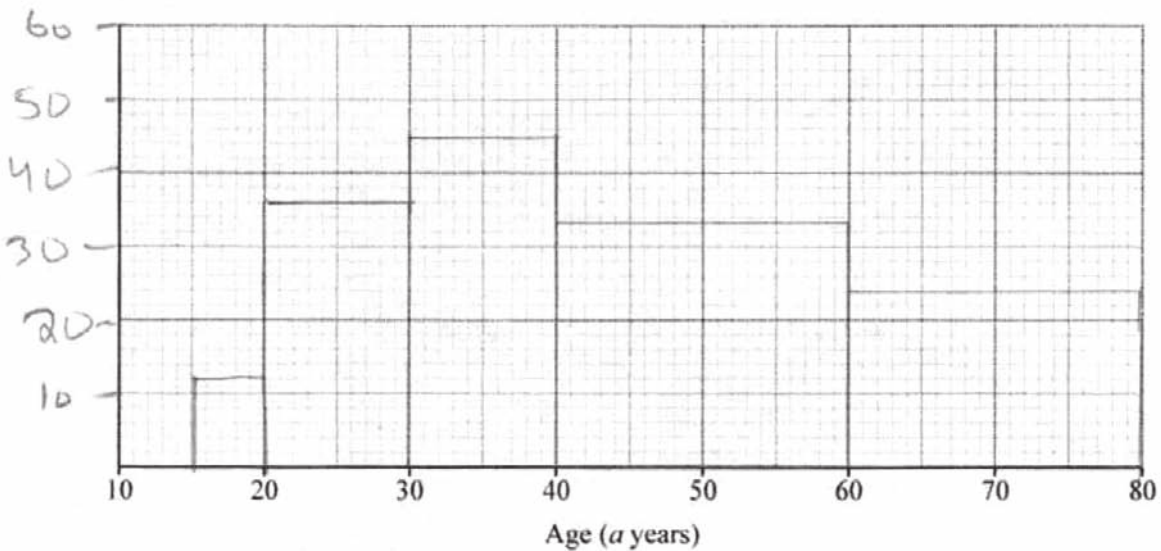

[3]

(iii) Find an estimate for the number of members of the film club who are over 50.

$= 33 + 24$

Answer 57 [1]

Examiner comment – grade C

- (a) (i) No working is shown, so it is difficult to know where the answer 36000 comes from.
(ii) A good answer, with the candidate going straight from $66/360$ to the correct, simplified answer of $11/60$. This is a part where many candidates struggled to find this simplified value.
(iii) Relatively few candidates realised that going straight to the difference in the angles was a quick way to tackle this question but unfortunately no further progress was made. Most candidates, even very strong ones, worked out the number for each of candidates *A* and *C* and then subtracted.

Mark awarded = 1 out of 5

- (b) (i) An excellent answer, with clear working shown and accurate arithmetic. The candidate did not fall into the trap of approximating to the nearest whole number.
(ii) This is the usual mistake of using frequencies instead of frequency densities.
(iii) Another common error, finding the number of members over 40, and not realising that candidates were expected to see that as there were 33 members between 40 and 60 it was necessary to estimate how many of those were between 50 and 60.

Mark awarded = 4 out of 7

Total mark awarded = 5 out of 12

Example candidate response – grade E

7 (a) The pie chart summarises the results of a local election.

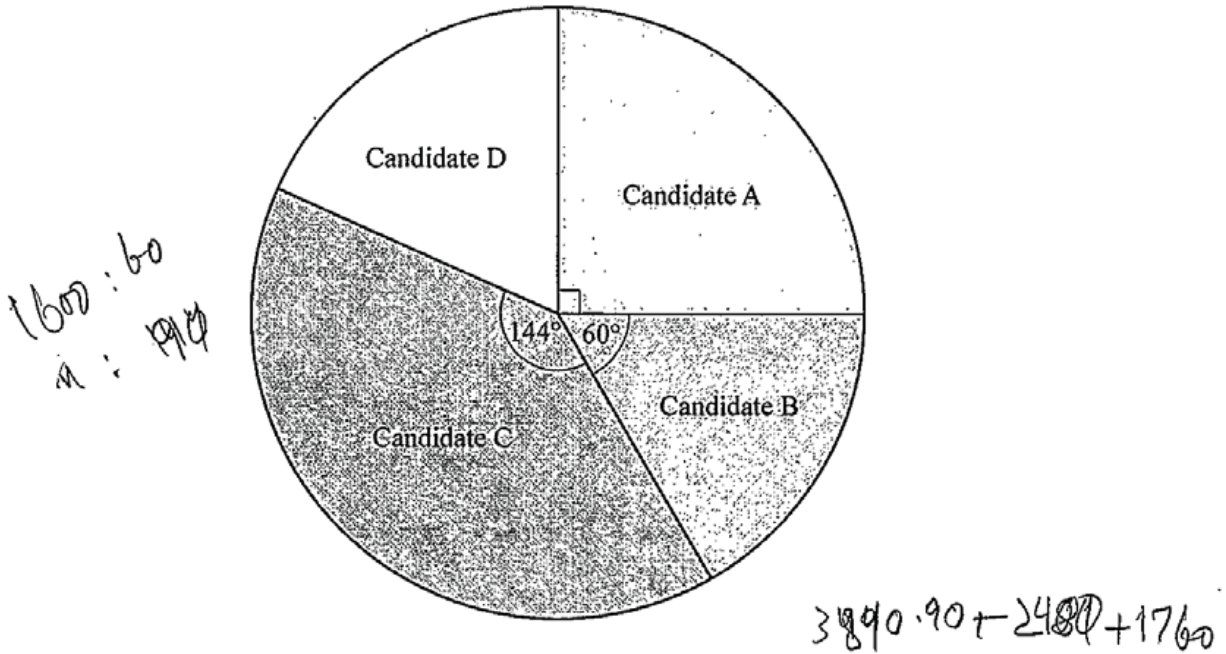

(i) Candidate B received 1600 votes.

Work out the total number of people who voted in the election.

Handwritten calculations for part (i):

$$1600 : 60 = 3840$$

$$1600 : 60 = 2400$$

$$1600 : 60 = 1760$$

Final calculation: $3840 + 2400 + 1760 = 8000$

Answer 8000 [2]

(ii) What fraction of the vote did candidate D receive?
Give your answer in its lowest terms.

Handwritten answer for part (ii):

Answer $\frac{4}{45}$ [1]

(iii) How many more votes than candidate A did candidate C receive?

Handwritten answer for part (iii):

Answer 1440 [2]

(b) The table summarises the ages of the members of a film club.

Age (a years)	$15 \leq a < 20$	$20 \leq a < 30$	$30 \leq a < 40$	$40 \leq a < 60$	$60 \leq a < 80$
Frequency	12	36	45	33	24

(i) Calculate an estimate of the mean age of the members.

$$\frac{5 \times 12 + 10 \times 36 + 10 \times 45 + 20 \times 33 + 20 \times 24}{150}$$

$$\frac{2010}{150} = 13.4$$

Answer 13.4 [3]

(ii) On the grid below, draw a histogram to represent this data.

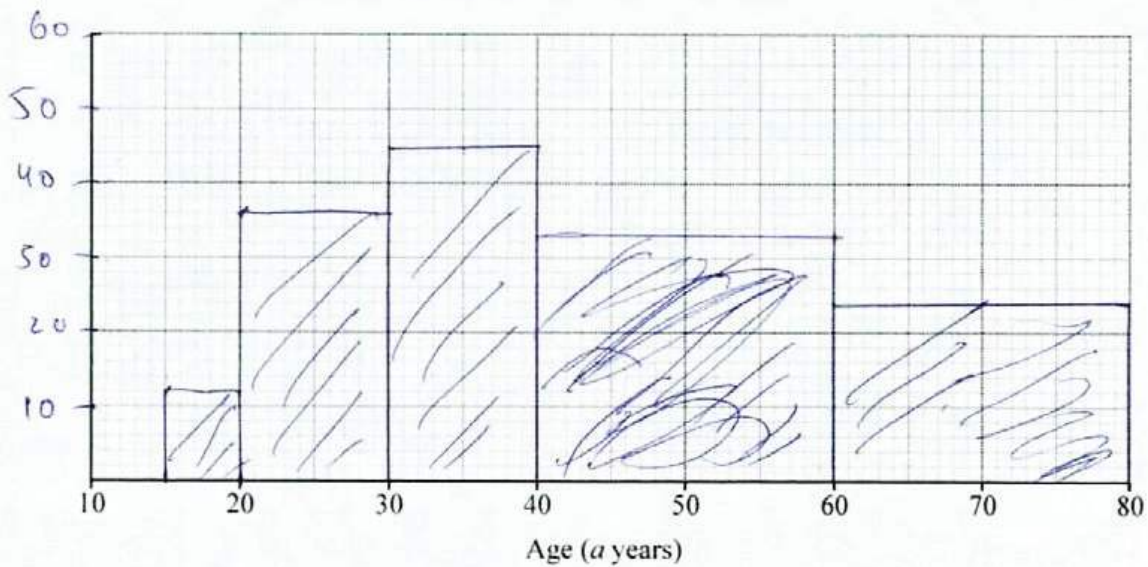

[3]

(iii) Find an estimate for the number of members of the film club who are over 50.

Answer 33 [1]

Examiner comment – grade E

- (a) (i) There is some good work here, but the candidate is using a long method, finding the number of votes for Candidates A , C , and D , but then forgetting that the votes for Candidate B had to be included.
- (ii) The work the candidate did in part (i) should have helped here, as the angle 66 had already been found and $66/360$ (simplified) was the answer required. It's difficult to know where the answer 4.45 came from. A quick reread of the question might well have helped the candidate here.
- (iii) The candidate gains some reward here for the work done in part (i).

Mark awarded = 2 out of 5

- (b) (i) This was a fairly common error, multiplying the frequency by the width of the intervals rather than the mid-points. Again, a quick check, by rereading the question, might have alerted the candidate to the fact that 13 could not be the average age of a group of people whose ages ranged from 15 to 80 .
- (ii) The candidate does not seem to understand the idea of frequency densities and gives a frequency diagram instead.
- (iii) It is difficult to know why the candidate gave the number of members between 40 and 60 .

Mark awarded = 2 out of 7

Total mark awarded = 4 out of 12

Question 8

Mark scheme

8	(a)	(i)	$\begin{pmatrix} 4 \\ -5 \end{pmatrix}$	1		
		(ii)	$6.4(0)$ to 6.41 or $\sqrt{41}$ cao	1		
		(iii)	$y = -1.25x + 7$ oe	2		
		(iv)	$(12, -8)$	2		
	(b)	(i)	(a)	$\mathbf{b} - \mathbf{a}$		1
			(b)	$3\mathbf{a}$ cao		1
			(c)	$4(\mathbf{b} - \mathbf{a})$		2
		(ii)	(a)	$1 : 4$		1
			(b)	$1 : 15$		1

Example candidate response – grade A

8 (a) In this question you may use the grid below to help you.

The point P has position vector $\begin{pmatrix} 4 \\ 2 \end{pmatrix}$ and the point Q has position vector $\begin{pmatrix} 8 \\ -3 \end{pmatrix}$.

(i) Find \overrightarrow{PQ} .

$$PQ = PO + OQ$$

$$= \begin{pmatrix} -4 \\ -2 \end{pmatrix} + \begin{pmatrix} 8 \\ -3 \end{pmatrix}$$

$$= \begin{pmatrix} 4 \\ -5 \end{pmatrix}$$

Answer $\begin{pmatrix} 4 \\ -5 \end{pmatrix}$ [1]

(ii) Find $|\overrightarrow{PQ}|$.

$$|PQ| = \sqrt{4^2 + (-5)^2}$$

$$= 6.40 \text{ (to 3 sig. fig.)}$$

Answer 6.40 units [1]

(iii) Find the equation of the line PQ .

$$m = -\frac{5}{4}$$

$$y - 2 = -\frac{5}{4}(x - 4)$$

$$y - 2 = -\frac{5}{4}x + 5 \quad \therefore y = -\frac{5}{4}x + 7 \quad \text{Answer } \dots\dots y = -\frac{5}{4}x + 7 \dots\dots [2]$$

(iv) Given that Q is the midpoint of the line PR , find the coordinates of R .

$$PQ = \frac{1}{2}PR$$

$$\begin{pmatrix} -4 \\ -5 \end{pmatrix} = \frac{1}{2} \begin{pmatrix} -4 \\ -2 \end{pmatrix} + OR$$

$$OR = \begin{pmatrix} -4 \\ -5 \end{pmatrix} - \begin{pmatrix} -2 \\ -1 \end{pmatrix}$$

$$\begin{pmatrix} -4 \\ -5 \end{pmatrix} = \frac{1}{2}PO + OR$$

$$\begin{pmatrix} -4 \\ -5 \end{pmatrix} = \begin{pmatrix} -2 \\ -1 \end{pmatrix} + OR$$

$$OR = \begin{pmatrix} -6 \\ -4 \end{pmatrix}$$

Answer (..... 6 , -4) [2]

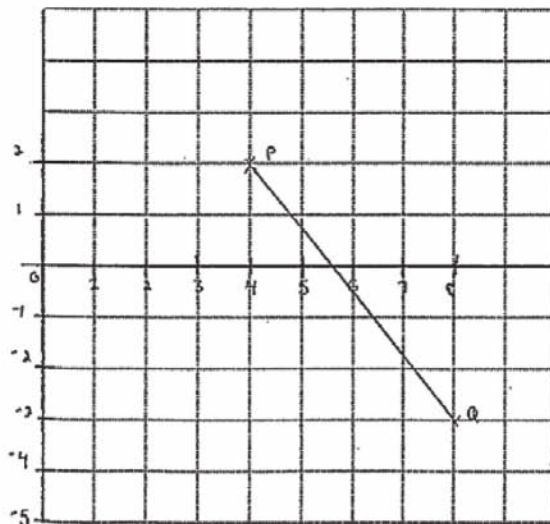

(b)

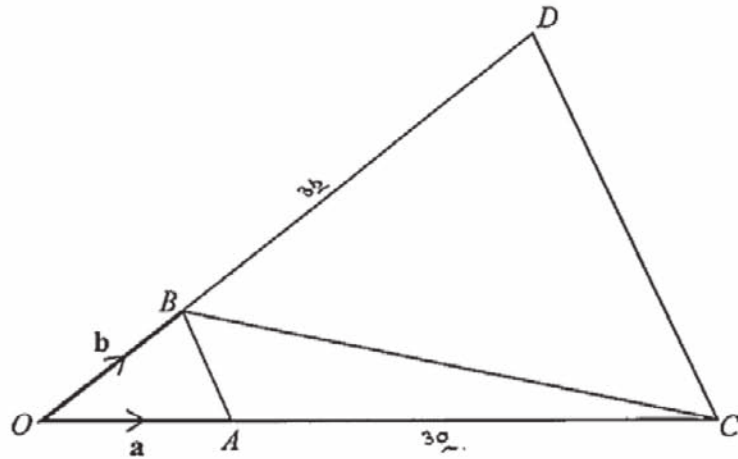

In the diagram triangles OAB and OCD are similar.

$\vec{OA} = \mathbf{a}$, $\vec{OB} = \mathbf{b}$ and $\vec{BC} = 4\mathbf{a} - \mathbf{b}$.

(i) Express, as simply as possible, in terms of \mathbf{a} and/or \mathbf{b}

(a) \vec{AB} ,

$$\begin{aligned} \vec{AB} &= \vec{AO} + \vec{OB} \\ &= -\mathbf{a} + \mathbf{b} \end{aligned}$$

Answer $\underline{-\mathbf{a} + \mathbf{b}}$ [1]

(b) \vec{AC} ,

$$\begin{aligned} \vec{AC} &= \vec{AB} + \vec{BC} \\ &= -\mathbf{a} + \mathbf{b} + 4\mathbf{a} - \mathbf{b} \\ &= 3\mathbf{a} \end{aligned}$$

Answer $\underline{3\mathbf{a}}$ [1]

(c) \vec{CD} .

$$\begin{aligned} \vec{CD} &= \vec{CO} + \vec{OD} \\ &= -4\mathbf{a} + 4\mathbf{b} \\ &= 4(\mathbf{b} - \mathbf{a}) \end{aligned}$$

Answer $\underline{4(\mathbf{b} - \mathbf{a})}$ [2]

(ii) Find, in its simplest form, the ratio

(a) perimeter of triangle OAB : perimeter of triangle OCD ,

Answer $\underline{1}$: $\underline{4}$ [1]

(b) area of triangle OAB : area of trapezium $ABDC$.

Answer $\underline{1}$: $\underline{16}$ [1]

Examiner comment – grade A

- (a) This was one of the less popular questions, with many candidates struggling with the vector notation.
- (i) A very neat solution from a strong candidate who clearly did understand the notation.
 - (ii) It is particularly pleasing to see the candidate clearly indicate that the answer has been given to three significant figures. This wasn't specified in the question but is stated in the general instructions on the front cover.
 - (iii) A fine answer with every step clearly shown.
 - (iv) The candidate tries to use a very good but difficult vector method and makes an error in the second line when the brackets are omitted in the expression $\frac{1}{2}(PO+OR)$ which results in $\frac{1}{2} OR$ being found rather than OR itself. Most candidates used the grid to mark the points and then tried to read off the coordinates of R .

Mark awarded = 4 out of 6

- (b) (i) All three parts are correctly answered and very well explained.
- (ii) After correctly finding the ratio of the two perimeters the candidate recognises (as very few do) that the ratio of the areas of similar figures is the square of the ratio of the lengths, i.e. 1 : 16 but forgets that the ratio required involves the trapezium, the difference between the two triangles, and should have been 1 : 15. Many candidates omitted this last part and of those who did attempt it, the most common wrong answers were 1 : 3 (recognising the subtraction but not the squaring) and 1 : 9 (recognising the squaring but using $OA : AC$).

Mark awarded = 5 out of 6

Total mark awarded = 9 out of 12

Example candidate response – grade C

8 (a) In this question you may use the grid below to help you.

The point P has position vector $\begin{pmatrix} 4 \\ 2 \end{pmatrix}$ and the point Q has position vector $\begin{pmatrix} 8 \\ -3 \end{pmatrix}$.

(i) Find \vec{PQ} .

$$\begin{aligned} &= \vec{OQ} - \vec{OP} \\ &= \begin{pmatrix} 8 \\ -3 \end{pmatrix} - \begin{pmatrix} 4 \\ 2 \end{pmatrix} = \begin{pmatrix} 4 \\ -5 \end{pmatrix} \\ &= \begin{pmatrix} 8-4 \\ -3-2 \end{pmatrix} \end{aligned}$$

Answer $\begin{pmatrix} 4 \\ -5 \end{pmatrix}$ [1]

(ii) Find $|\vec{PQ}|$.

$$\begin{aligned} &= \sqrt{a^2 + b^2} \\ &= \sqrt{4^2 + (-5)^2} \\ &= \sqrt{16 + 25} \end{aligned}$$

$$\begin{aligned} &= \sqrt{41} \\ &= 6.4031 \end{aligned}$$

Answer 6.4031 [1]

(iii) Find the equation of the line PQ .

$$\begin{aligned} &= \begin{pmatrix} x_1 \\ y_1 \end{pmatrix} \begin{pmatrix} x_2 \\ y_2 \end{pmatrix} = \begin{pmatrix} 4 \\ 2 \end{pmatrix} \begin{pmatrix} 8 \\ -3 \end{pmatrix} \\ &= \frac{y_2 - y_1}{x_2 - x_1} \\ &= \frac{-3 - 2}{8 - 4} = -\frac{5}{4} \end{aligned}$$

eq. of line \Rightarrow
 $y - y_1 = m(x - x_1)$
 $y - 2 = -1.25(x - 4)$
 $y - 2 = -1.25x + 5$
 $y = -1.25x + 7$
 $y = -1.25x + 7$

Answer $y = -1.25x + 7$ [2]

(iv) Given that Q is the midpoint of the line PR , find the coordinates of R .

Answer (..... 10, -5) [2]

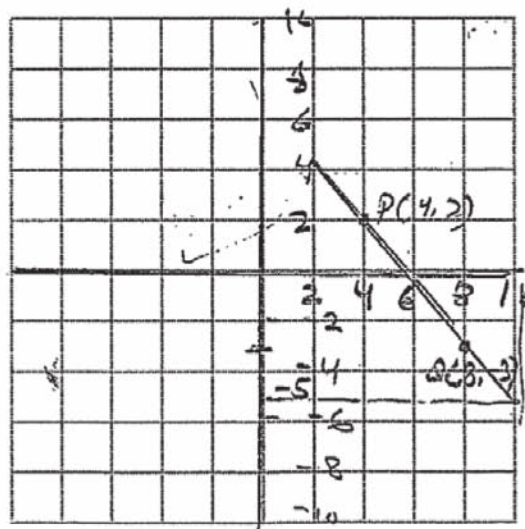

(b)

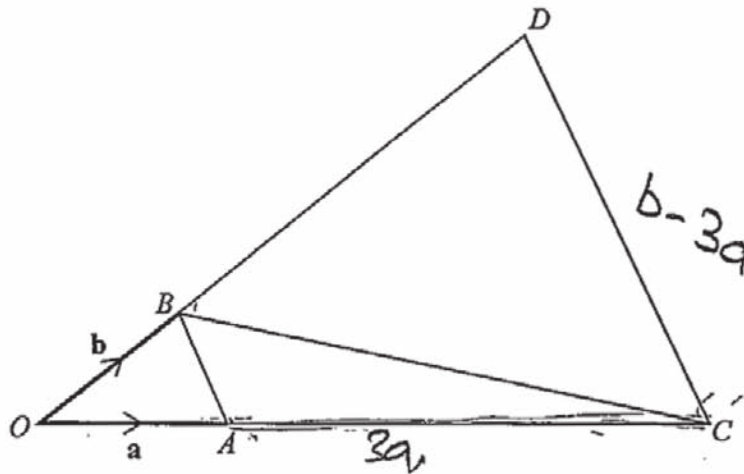

In the diagram triangles OAB and OCD are similar.

$\vec{OA} = \mathbf{a}$, $\vec{OB} = \mathbf{b}$ and $\vec{BC} = 4\mathbf{a} - \mathbf{b}$.

(i) Express, as simply as possible, in terms of \mathbf{a} and/or \mathbf{b}

(a) $\vec{AB} = \vec{OB} - \vec{OA} = \mathbf{b} - \mathbf{a}$

Answer $\mathbf{b} - \mathbf{a}$ [1]

(b) $\vec{AC} = \vec{OC} - \vec{OA} = \vec{OB} + \vec{BC} - \vec{OA} = \mathbf{b} + 4\mathbf{a} - \mathbf{a} = \mathbf{b} + 3\mathbf{a}$

Answer $\mathbf{b} + 3\mathbf{a}$ [1]

(c) $\vec{CD} = \vec{OD} - \vec{OC} = \vec{OB} + \vec{BD} - \vec{OC} = \mathbf{b} - 3\mathbf{a}$

Answer $\mathbf{b} - 3\mathbf{a}$ [2]

(ii) Find, in its simplest form, the ratio

(a) perimeter of triangle OAB : perimeter of triangle OCD ,

$OAB = a + b + b - a = 2b$
 $OCD = a + b + 3a + b - 3a = 2b + a$

Answer $2b : 2b + a$ [1]

(b) area of triangle OAB : area of trapezium $ABDC$:

$OAB = \frac{1}{2}(b-a)(b)$
 $= \frac{1}{2}(ab - a^2)$
 ii) $\frac{1}{2} \times h \times \text{sum of // sides} = \frac{1}{2} \times (b-3a) \times (3a+b)$
 $= \frac{1}{2}(3ab + b^2 - 9a^2 - 3ab) = \frac{1}{2}(b^2 - 9a^2)$

Answer $\frac{ab - a^2}{2} : \frac{b^2 - 9a^2}{2}$ [1]

Examiner comment – grade C

- (a)** The first three parts were all completed successfully and all necessary working shown, but the fourth part caused problems. The grid was used but although the ideas appeared to be there, the candidate became confused and could not get to the final answer. A clearer diagram would have helped.

Mark awarded = 4 out of 6

- (b) (i)** Parts **(a)** and **(b)** were answered correctly but the candidate did not realise that the value that had been found for vector AC in **(ii)** should be used to find vector OC , and hence it became impossible to make further progress.
- (ii)** The candidate was now unable to find the two ratios in this part. In fact many candidates did not realise that the two answers had to be numerical and very many answers involved complicated vector expressions.

Mark awarded = 2 out of 6

Total mark awarded = 6 out of 12

Example candidate response – grade E

8 (a) In this question you may use the grid below to help you.

The point P has position vector $\begin{pmatrix} 4 \\ 2 \end{pmatrix}$ and the point Q has position vector $\begin{pmatrix} 8 \\ -3 \end{pmatrix}$.

(i) Find \overrightarrow{PQ} .

$$\begin{bmatrix} 4 \\ 2 \end{bmatrix} - \begin{bmatrix} 8 \\ -3 \end{bmatrix} = \begin{bmatrix} -4 \\ 5 \end{bmatrix}$$

Answer $\begin{pmatrix} \\ \end{pmatrix}$ [1]

(ii) Find $|\overrightarrow{PQ}|$.

$$= \sqrt{(8-4)^2 + (-3-2)^2}$$

$$\sqrt{(x_2-x_1)^2 + (y_2-y_1)^2} \quad \sqrt{16+1}$$

$$\sqrt{17}$$

Answer 4.12 [1]

(iii) Find the equation of the line PQ .

$$y = mx + c$$

$$2 = -1.25(4) + c$$

$$2 - 5 = c$$

$$-3 = c$$

$$m = \frac{y_2 - y_1}{x_2 - x_1} = \frac{-3 - 2}{8 - 4} = \frac{-5}{4} = -1.25$$

Answer $y = -1.25x + c$ [2]

(iv) Given that Q is the midpoint of the line PR , find the coordinates of R .

$$\frac{x_1 + x_2}{2} = \frac{y_1 + y_2}{2}$$

$$\frac{4 + x_2}{2} = \frac{2 + (-3)}{2}$$

$$\frac{4 + x_2}{2} = -\frac{1}{2}$$

$$4 + x_2 = -1$$

$$x_2 = -5$$

Answer (..... -5....., -2.....) [2]

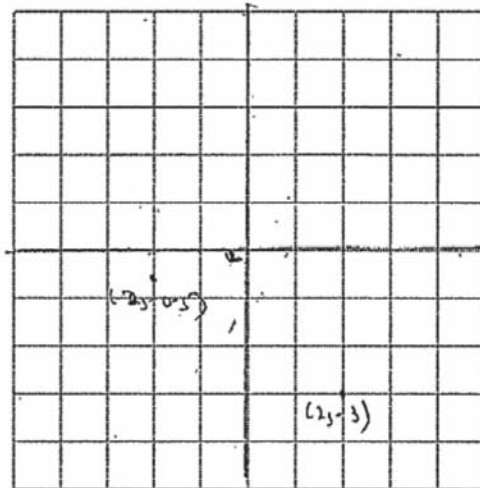

(b)

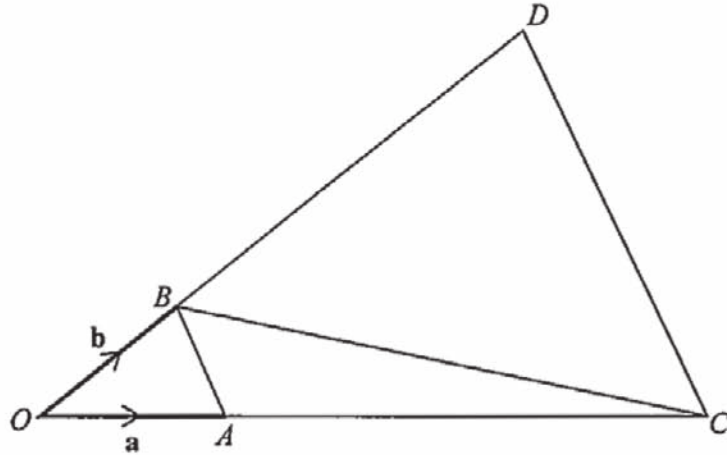

In the diagram triangles OAB and OCD are similar.

$\vec{OA} = a$, $\vec{OB} = b$ and $\vec{BC} = 4a - b$.

(i) Express, as simply as possible, in terms of a and/or b

(a) \vec{AB} ,

Answer $-a + b$ [1]

(b) \vec{AC} ,

$-a + b + 4a - b$
 $3a$

Answer $-a + b + 4a - b = 3a$ [1]

(c) \vec{CD} .

$-4a + b + 3b$

Answer $-b$ [2]

(ii) Find, in its simplest form, the ratio

(a) perimeter of triangle OAB : perimeter of triangle OCD ,

$-a + b + a + b$

$a + 3a - b$

Answer $2b$: $4a - b$ [1]

(b) area of triangle OAB : area of trapezium $ABDC$.

$\frac{-a + 2b}{2}$ $\frac{-a + 2b + b}{2}$

Answer $a \times b$: $\frac{1}{2} \times (-a + 2b + b) \times b$ [1]

Examiner comment – grade E

- (a) Relatively few candidates at this ability level made a significant attempt at this question, with many omitting it altogether.
- (i) This candidate demonstrates some understanding of the vector notation but unfortunately finds $OP - OQ$ instead of $OQ - OP$. Use of the grid might have helped.
 - (ii) Again, the candidate has some idea of what is required, but, instead of using the previous answer, starts again and although realising that Pythagoras's theorem should be used, is not able to deal with the double negative.
 - (iii) The first mark is earned by calculating the gradient correctly but the second is lost when a sign error is made as the intercept is attempted.
 - (iv) This is a difficult part and the candidate does not understand what is being asked, giving two points as the answer.

Mark awarded = 1 out of 5

- (b) (i) The candidate successfully answers the first two parts and the working suggests that the third part might have been successfully completed with a little more care.
- (ii) This part of the question then proves to be too difficult, with both answers being given in terms of vectors.

Mark awarded = 2 out of 6

Total mark awarded = 3 out of 12

Question 9

Mark scheme

9	(a)	$\sqrt{15^2 + 6^2} = 16.15(5\dots)$	1	Must be shown to at least 2 d.p.
	(b)	417 to 419	3	M1 for $\pi \times 6 \times 16.2$ soi by 305.4 M1 for $\pi \times 6^2$ soi by 113.1
	(c)	565 to 566	2	M1 for $\frac{1}{3} \times \pi \times 6^2 \times 15$ or better
	(d)	316 to 317	2FT	FT <i>their</i> (c) $\times 0.56$ evaluated B1 for figs 316(...) or 317(...) or <i>their</i> (c) \times figs 56 evaluated
	(e) (i)	18.89 to 18.9	2	M1 for $\sqrt[3]{2}$ or 1.25... seen oe
	(ii)	662 to 665	2	M1 for $(\sqrt[3]{2})^2$ or 1.58... seen oe

Example candidate response – grade A

9 [Volume of a cone = $\frac{1}{3}\pi r^2 h$]

[Curved surface area of a cone = $\pi r l$]

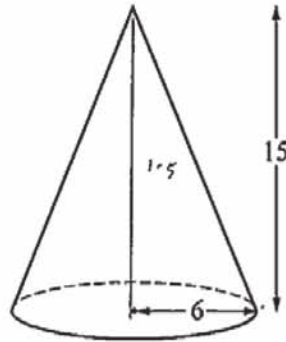

The diagram shows a solid cone of height 15 cm and base radius 6 cm.

- (a) Show that the slant height of the cone is 16.2 cm, correct to one decimal place.

$$\begin{aligned} \text{slant height} &= \sqrt{15^2 + 6^2} \\ x^2 &= 225 + 36 \\ &= 261 \\ x &= \sqrt{261} \\ &= 16.15 \\ &= 16.2 \text{ cm} \end{aligned}$$

[1]

- (b) Calculate the total surface area of the cone.

$$\begin{aligned} \text{C.S.A} &= \pi \times 6 \times 16.2 \\ &= 305.4 \\ \text{Circle area} &= \pi r^2 \\ &= 113.1 \\ \text{Total} &= 418.5 \end{aligned}$$

Answer 418.5 cm² [3]

- (c) Calculate the volume of the cone.

$$\begin{aligned} \text{volume} &= \frac{1}{3} \pi 6^2 \times 15 \\ &= 564.5 \\ &= 565 \text{ (3 s.f)} \end{aligned}$$

Answer 565 cm³ [2]

$$\begin{aligned} 1 \times 14 &= 100 + 100 + 100 \\ &= 1000000 \\ &= 565 \end{aligned}$$

$$= 0.000565$$

- (d) The cone is made from wood.
The mass of 1 m^3 of the wood is 560 kg.

Calculate the mass of the cone in grams.

$$1 \text{ m}^3 = 560 \text{ kg}$$

$$1 \text{ kg} = \frac{1000 \text{ g}}{1000} = 1 \text{ g}$$

$$0.000565 \times 0.56 = \text{Answer } \dots\dots\dots 6.0003164 \dots\dots\dots \text{ g [2]}$$

- (e) Another cone is made of the same material and is geometrically similar to the first.
The mass of the second cone is double the mass of the first.

- (i) Calculate the height of the second cone.
- $$\left(\frac{15}{x}\right)^3 = \frac{565}{1130}$$

$$x = 18.9.$$

Answer $\dots\dots\dots 18.9 \dots\dots\dots$ cm [2]

- (ii) Calculate the total surface area of the second cone.

$$\frac{18.9^2}{15^2} \times 418.5 = x$$

$$= 527.31$$

Answer $\dots\dots\dots 527.31 \dots\dots\dots$ cm² [2]

Examiner comment – grade A

- (a) The candidate has clearly shown the method used and how the four figures have been corrected to three.

Mark awarded = 1 out of 1

- (b) Accurate working earns all three marks.

Mark awarded = 3 out of 3

- (c) The candidate gives the correct expression which is to be used and arrives at the correct answer of 565, so although there is a slight slip in the intermediate line, full marks have been awarded.

Mark awarded = 2 out of 2

- (d) This proved to be quite a difficult part, with two problems to negotiate – the idea of density and that of units (grams/kilograms and cubic centimetres/cubic metres). Here the candidate managed the density idea but not the units, finishing with the correct figures but with the decimal point in the wrong place, which earned one of the two marks.

Mark awarded = 1 out of 2

- (e) These two parts were even more difficult and few candidates gained all four marks. This candidate starts well in part (i), recognising the cubic relationship, and although putting in a strange intermediate step, recovers to get the correct answer and both marks. In part (ii), however, the common error of using the linear relationship is seen and no marks earned.

Mark awarded = 2 out of 4

Total mark awarded = 9 out of 12

Example candidate response – grade C

- 9 [Volume of a cone = $\frac{1}{3}\pi r^2 h$]
[Curved surface area of a cone = $\pi r l$]

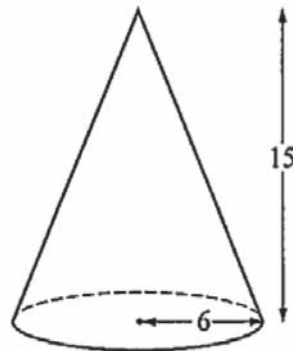

The diagram shows a solid cone of height 15 cm and base radius 6 cm.

- (a) Show that the slant height of the cone is 16.2 cm, correct to one decimal place.

$$H^2 = B^2 + P^2$$

$$= \sqrt{6^2 + 15^2}$$

$$H = 16.15 \approx 16.2$$

[1]

- (b) Calculate the total surface area of the cone.

$$\begin{aligned} \text{T.S.A. of Cone} &= \pi r (l + r) \\ &= \pi (6) (15 + 6) \\ &= \pi (6) (16.2 + 6) \\ &= \pi (6) (16.2 + 6) \\ &= 18.84 (16.2 + 6) \end{aligned}$$

= 418.248 cm²

Answer 418.248 cm² [3]

- (c) Calculate the volume of the cone.

$$\begin{aligned} \text{Volume of the cone} &= \frac{1}{3} \pi r^2 h \\ &= \frac{1}{3} \pi (6)^2 \times 15 \\ &= 565.48 \text{ cm}^3 \end{aligned}$$

Answer 565.48 cm³ [2]

- (d) The cone is made from wood.
The mass of 1 m^3 of the wood is 560 kg.

Calculate the mass of the cone in grams.

$$1 \text{ m}^3 : 560 \text{ kg}$$
~~$$1 \text{ m}^3 : 560000 \text{ g}$$~~

$$1 \text{ m}^3 : x$$

$$x = 560 \times 100 \times 100 \times 100$$

$$= 56000000 \text{ g}$$

Answer 56000000 g [2]

- (e) Another cone is made of the same material and is geometrically similar to the first.
The mass of the second cone is double the mass of the first.

- (i) Calculate the height of the second cone.

$$\frac{m_1}{m_2} = \left(\frac{l_1}{l_2} \right)^2$$

$$\frac{56000000}{2(56000000)} = \left(\frac{16.2}{l_2} \right)^2$$

Answer 524.9 cm [2]

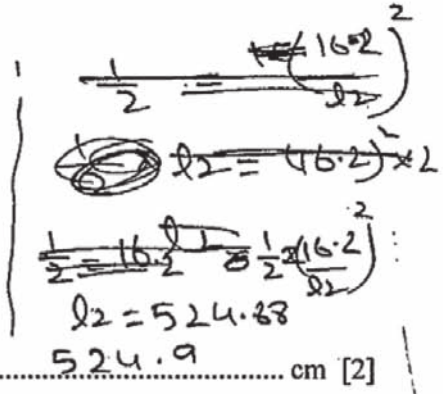

- (ii) Calculate the total surface area of the second cone.

$$T.S.A = \pi r(l+r)$$

$$= \pi (12)(524.9+12)$$

$$= 20240.65 \text{ cm}^2$$

Answer 20240.65 cm² [2]

Examiner comment – grade C

(a) Clear working shown and the correct answer given.

Mark awarded = 1 out of 1

(b) Well answered and all marks earned.

Mark awarded = 3 out of 3

(c) This is a fairly straightforward part and the candidate gains both marks.

Mark awarded = 2 out of 2

(d) This was a fairly common error attempting to deal with the change of units but ignoring the situation of the question and the previously calculated mass of the cone.

Mark awarded = 0 out of 2

- (e) (i) The candidate realised that this was not a linear relationship but unfortunately used the square instead of the cubic one required. There was a further error when the slant height was used instead of the vertical height.
- (ii) The candidate then attempts to find the total surface area by going back to the basic formula, but now falls into the trap avoided in part (i) of thinking that the connection is linear and therefore the radius doubled.

Mark awarded = 0 out of 4

Total mark awarded = 6 out of 12

Example candidate response – grade E

9 [Volume of a cone = $\frac{1}{3}\pi r^2 h$]

[Curved surface area of a cone = $\pi r l$]

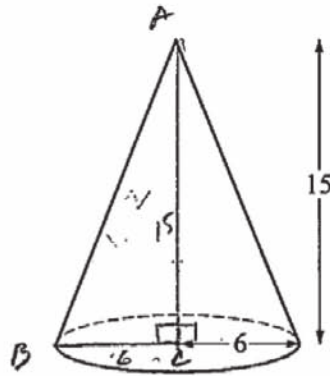

The diagram shows a solid cone of height 15 cm and base radius 6 cm.

- (a) Show that the slant height of the cone is 16.2 cm, correct to one decimal place.

$$AB^2 = BE^2 + AE^2$$

$$AB^2 = 36 + 225$$

$$AB = \sqrt{261}$$

$$AB = 16.2 \text{ . Shown.}$$

[1]

- (b) Calculate the total surface area of the cone.

Vol of the cone + curved surface area of a cone

$$\frac{1}{3} \pi r^2 h + \pi r l$$

$$\frac{1}{3} \times \pi \times 6^2 \times 15 + \pi \times 6 \times 16.2$$

$$= 870.8 \text{ cm}^2$$

Answer 870.8 cm² [3]

- (c) Calculate the volume of the cone.

$$\frac{1}{3} \pi 6^2 \times 15$$

$$= 565.4 \text{ cm}^3$$

Answer 565 cm³ cm³ [2]

- (d) The cone is made from wood.
The mass of 1 m^3 of the wood is 560 kg.

Calculate the mass of the cone in grams.

$$\frac{560}{100} = 5.6 \text{ g.}$$

Answer 5.6 g [2]

- (e) Another cone is made of the same material and is geometrically similar to the first.
The mass of the second cone is double the mass of the first.

- (i) Calculate the height of the second cone.

$$15 \times 2 = 30 \text{ cm}$$

Answer 30 cm [2]

- (ii) Calculate the total surface area of the second cone.

~~$$\frac{1}{3} \pi r^2 h + \pi r l$$~~

'total' surface area of the first cone $\times 2$

$$= 870.8 \times 2$$

$$= 1741.6 \text{ cm}^2$$

Answer 1741.6 cm^2 [2]

Examiner comment – grade E

- (a) The candidate correctly uses Pythagoras's theorem to find the slant height but does not show why the stated value is given 'correct to one decimal place'. The working should show16.155... = 16.2.

Mark awarded = 0 out of 1

- (b) Although the candidate mixes volumes and areas, the working does show a correct expression for one part of the total area and so gains one mark.

Mark awarded = 1 out of 3

- (c) The volume of the cone is found accurately and both marks awarded.

Mark awarded = 2 out of 2

- (d) The candidate simply tries to convert cubic kilograms into cubic grams, although incorrectly dividing by 100, and doesn't involve the mass of the cone at all.

Mark awarded = 0 out of 2

- (e) This was a particularly difficult question and the candidate did not understand what was required. It was assumed that both relationships were linear and so the candidate just doubled the original height and the answer to part (b).

Mark awarded = 0 out of 4

Total mark awarded = 3 out of 12

Question 10

Mark scheme

10 (a)	$[L =] \quad 2\left(x + \frac{50}{x}\right) \text{ or } 2x + 2\frac{50}{x}$ or $x + x + \frac{50}{x} + \frac{50}{x}$	2	B1 for $\frac{50}{x}$ seen
(b)	41.5 to 41.6, 45	2	B1 for one correct
(c)	Correct smooth curve through the eight given points correctly plotted on correctly scaled axes	3	\pm half a small square B2 for seven or eight of the given points correctly plotted on <i>their</i> axes or B1 for six of the given points correctly plotted on <i>their</i> axes
(d)	$2.8 \text{ to } 3.2 < x < 16.8 \text{ to } 17.2$	B1 B1	M1 for attempt to read off two x values at $y = 40$
(e) (i)	$27.5 < \text{answer} < 28.5$	1	
(ii)	7, 7 cao	1	
(f)	10, 10 cao	1	

Example candidate response – grade A

- 10 Adil wants to fence off some land as an enclosure for his chickens. The enclosure will be a rectangle with an area of 50 m^2 .

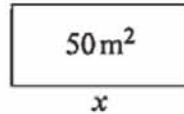

- (a) The enclosure is x m long.

Show that the total length of fencing, L m, required for the enclosure is given by

$$L = 2x + \frac{100}{x}$$

$L = x + x$
 $50 = L \times b$
 $50 = x \times L$
 $\frac{50}{x} = 2x = \frac{100}{x}$

[2]

- (b) The table below shows some values of x and the corresponding values of L , correct to one decimal place where appropriate, for $L = 2x + \frac{100}{x}$.

x	2	4	6	8	10	12	14	16	18	20
L	54	33	28.7	28.5	30	32.3	35.1	38.3	41.5	45

41.5

Complete the table.

[2]

- (c) On the grid opposite draw a horizontal x -axis for $0 \leq x \leq 20$ using a scale of 1 cm to represent 2 m and a vertical L -axis for $0 \leq L \leq 60$ using a scale of 2 cm to represent 10 m.

On the grid, plot the points given in the table and join them with a smooth curve.

[3]

- (d) Adil only has 40 m of fencing.

Use your graph to find the range of values of x that he can choose.

Answer $2.8 \leq x \leq 17.2$ [2]

- (e) (i) Find the minimum length of fencing Adil could use for the enclosure.

Answer 7.1 m [1]

- (ii) Find the length and width of the enclosure using this minimum length of fencing. Give your answers correct to the nearest metre.

Answer Length = 7 m Width = 7 m [1]

- (f) Suggest a suitable length and width for an enclosure of area 100m^2 , that uses the minimum possible length of fencing.

Answer Length =¹⁴..... m Width =¹⁴..... m [1]

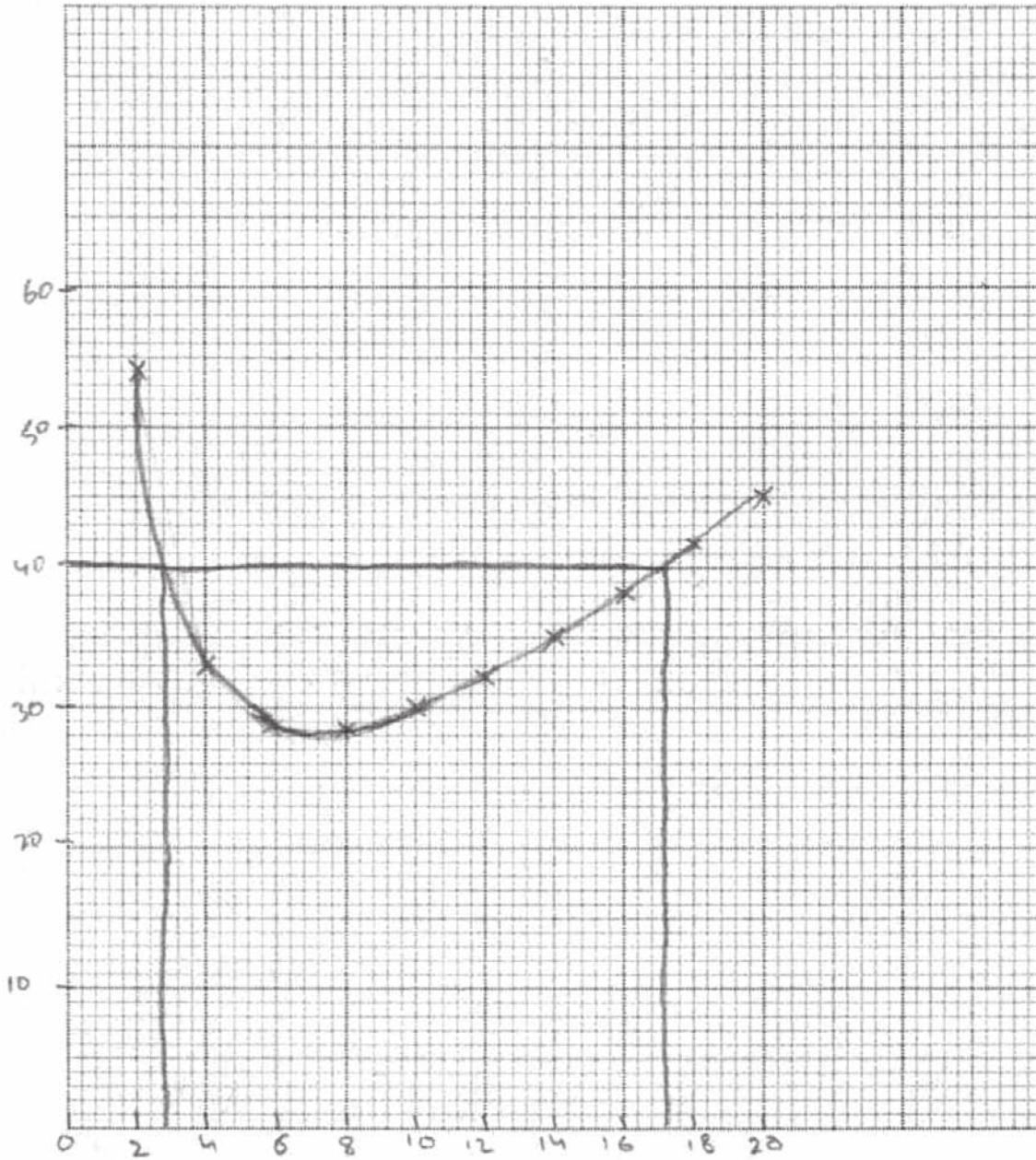

Examiner comment – grade A

- (a) Although not perfect, with one or two strange statements ($L = x + x$ and $50 / x = 2x$), it is clear what the candidate intends and both marks are awarded.

Mark awarded = 2 out of 2

- (b) The 41.5 is not quite accurate, it should be 41.6, but it is within the acceptable range.

Mark awarded = 2 out of 2

- (c) The points and the curve are just within the tolerances allowed so all three marks are allowed.

Mark awarded = 3 out of 3

- (d) The candidate understands the situation and reads off two acceptable values. Many candidates gave only one value.

Mark awarded = 2 out of 2

- (e) (i) The candidate has identified the minimum point of the curve as the point to be used but has then read off the value of x rather than the length of fencing.
(ii) This value of x does, however, now lead the candidate to the answer to this part, and correct answers to this part are very rare.

Mark awarded = 1 out of 2

- (f) The candidate now realises that a square is again required (again very few did) but unfortunately assumed that doubling the area means doubling the lengths.

Mark awarded = 0 out of 1

Total mark awarded = 10 out of 12

Example candidate response – grade C

- 10 Adil wants to fence off some land as an enclosure for his chickens. The enclosure will be a rectangle with an area of 50 m^2 .

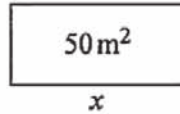

- (a) The enclosure is x m long.

Show that the total length of fencing, L m, required for the enclosure is given by

$$L = 2x + \frac{100}{x}$$

$$50 = \frac{2x^2 + 100}{x}$$

$$50x - 2x^2 = 100$$

$$-2x^2 + 50x - 100 = 0$$

[2]

- (b) The table below shows some values of x and the corresponding values of L , correct to one decimal place where appropriate, for $L = 2x + \frac{100}{x}$.

x	2	4	6	8	10	12	14	16	18	20
L	54	33	28.7	28.5	30	32.3	35.1	38.3	41.6	45

Complete the table.

[2]

- (c) On the grid opposite draw a horizontal x -axis for $0 \leq x \leq 20$ using a scale of 1 cm to represent 2 m and a vertical L -axis for $0 \leq L \leq 60$ using a scale of 2 cm to represent 10 m.

On the grid, plot the points given in the table and join them with a smooth curve.

[3]

- (d) Adil only has 40 m of fencing.

Use your graph to find the range of values of x that he can choose.

Answer 3 $\leq x \leq$ 17.5 [2]

- (e) (i) Find the minimum length of fencing Adil could use for the enclosure.

Answer 2 m [1]

- (ii) Find the length and width of the enclosure using this minimum length of fencing. Give your answers correct to the nearest metre.

Answer Length = 28.5 m Width = 8 m [1]

(f) Suggest a suitable length and width for an enclosure of area 100 m^2 , that uses the minimum possible length of fencing.

Answer Length = 39 m Width = 4.2 m [1]

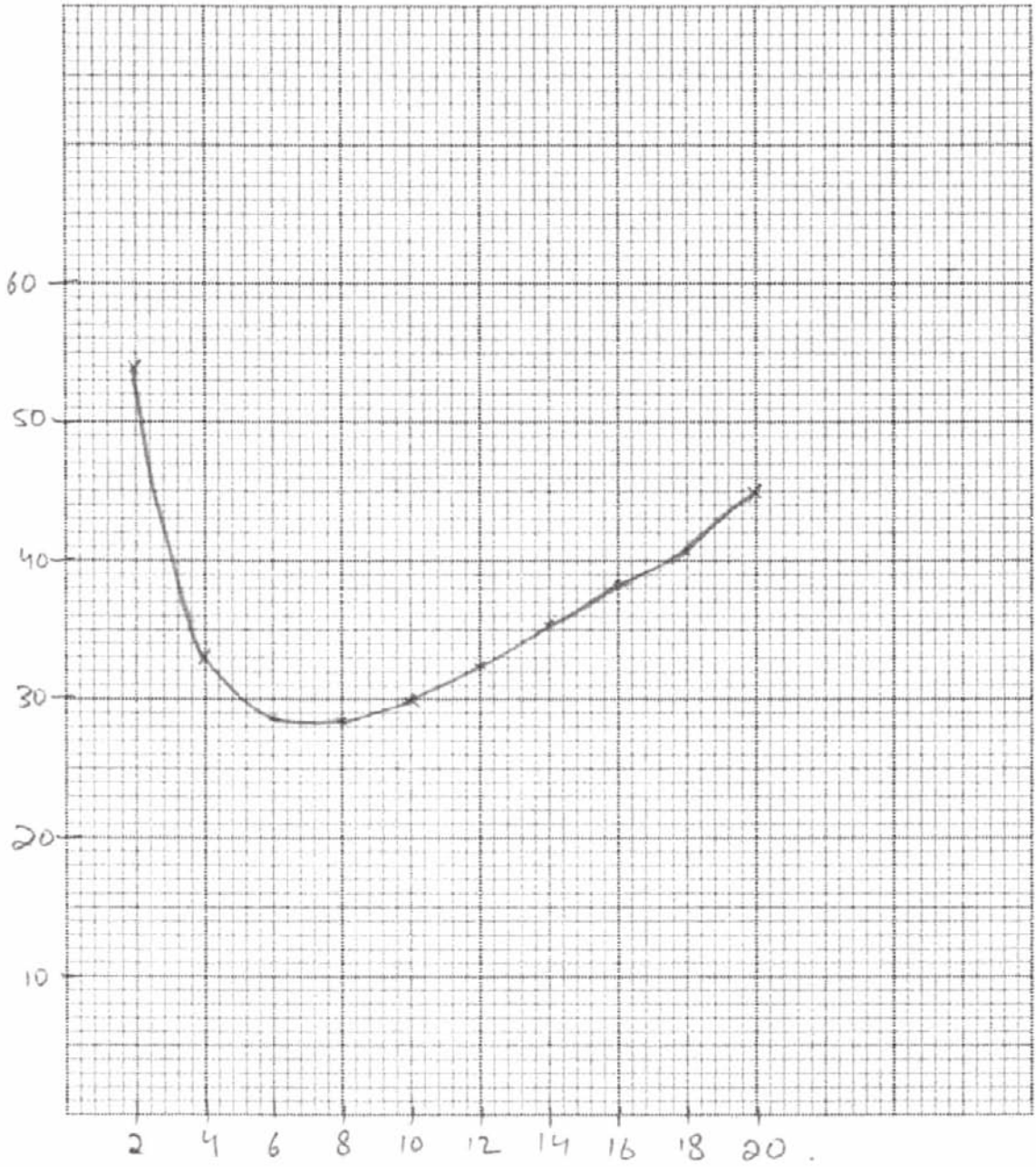

Examiner comment – grade C

- (a) The candidate did not realise what is involved here, thinking that the 50 is the length of fencing and tries to manipulate the resulting expression.

Mark awarded = 0 out of 2

- (b) Both values are given correctly.

Mark awarded = 2 out of 2

- (c) All the given points are plotted accurately and although there is a slight error with the 41.6 the candidate gains all three marks for plotting the first eight points correctly.

Mark awarded = 3 out of 3

- (d) Unfortunately the slight error mentioned above causes the second answer to be outside the acceptable range.

Mark awarded = 1 out of 2

- (e) The candidate now appears to misunderstand the question and it is difficult to see the relevance of the answers.

Mark awarded = 0 out of 2

- (f) The candidate again appears confused but these last two parts, (e) and (f), proved to be very difficult and only the very strongest candidates achieved all three marks.

Mark awarded = 0 out of 1

Total mark awarded = 6 out of 12

Example candidate response – grade E

- 10 Adil wants to fence off some land as an enclosure for his chickens. The enclosure will be a rectangle with an area of 50 m^2 .

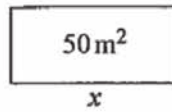

$$sp = 2L +$$

- (a) The enclosure is x m long.

Show that the total length of fencing, L m, required for the enclosure is given by

$$L = 2x + \frac{100}{x}$$

$$L = x(2 + 100/x)$$

$$L = x(102)$$

$$L = 102x$$

[2]

- (b) The table below shows some values of x and the corresponding values of L , correct to one decimal place where appropriate, for $L = 2x + \frac{100}{x}$.

x	2	4	6	8	10	12	14	16	18	20
L	54	33	28.7	28.5	30	32.3	35.1	38.3	41.5	45

Complete the table.

[2]

- (c) On the grid opposite draw a horizontal x -axis for $0 \leq x \leq 20$ using a scale of 1 cm to represent 2 m and a vertical L -axis for $0 \leq L \leq 60$ using a scale of 2 cm to represent 10 m.

On the grid, plot the points given in the table and join them with a smooth curve.

[3]

- (d) Adil only has 40 m of fencing.

Use your graph to find the range of values of x that he can choose.

$$\text{Answer } \dots\dots 6 \dots\dots \leq x \leq \dots\dots 20 \dots\dots [2]$$

- (e) (i) Find the minimum length of fencing Adil could use for the enclosure.

$$\text{Answer } \dots\dots 27 \dots\dots \text{ m } [1]$$

- (ii) Find the length and width of the enclosure using this minimum length of fencing. Give your answers correct to the nearest metre.

$$L = 2x + \frac{100}{x}$$

$$27x = 2x + 100$$

$$27x - 100 = 2x$$

$$27 - 100 = 2x - x$$

$$-73 = x$$

$$\text{Answer } \text{Length} = \dots\dots 26 \dots\dots \text{ m } \text{Width} = \dots\dots -73 \dots\dots \text{ m } [1]$$

- (f) Suggest a suitable length and width for an enclosure of area 100m^2 , that uses the minimum possible length of fencing.

Answer Length =32..... m Width =24..... m [1]

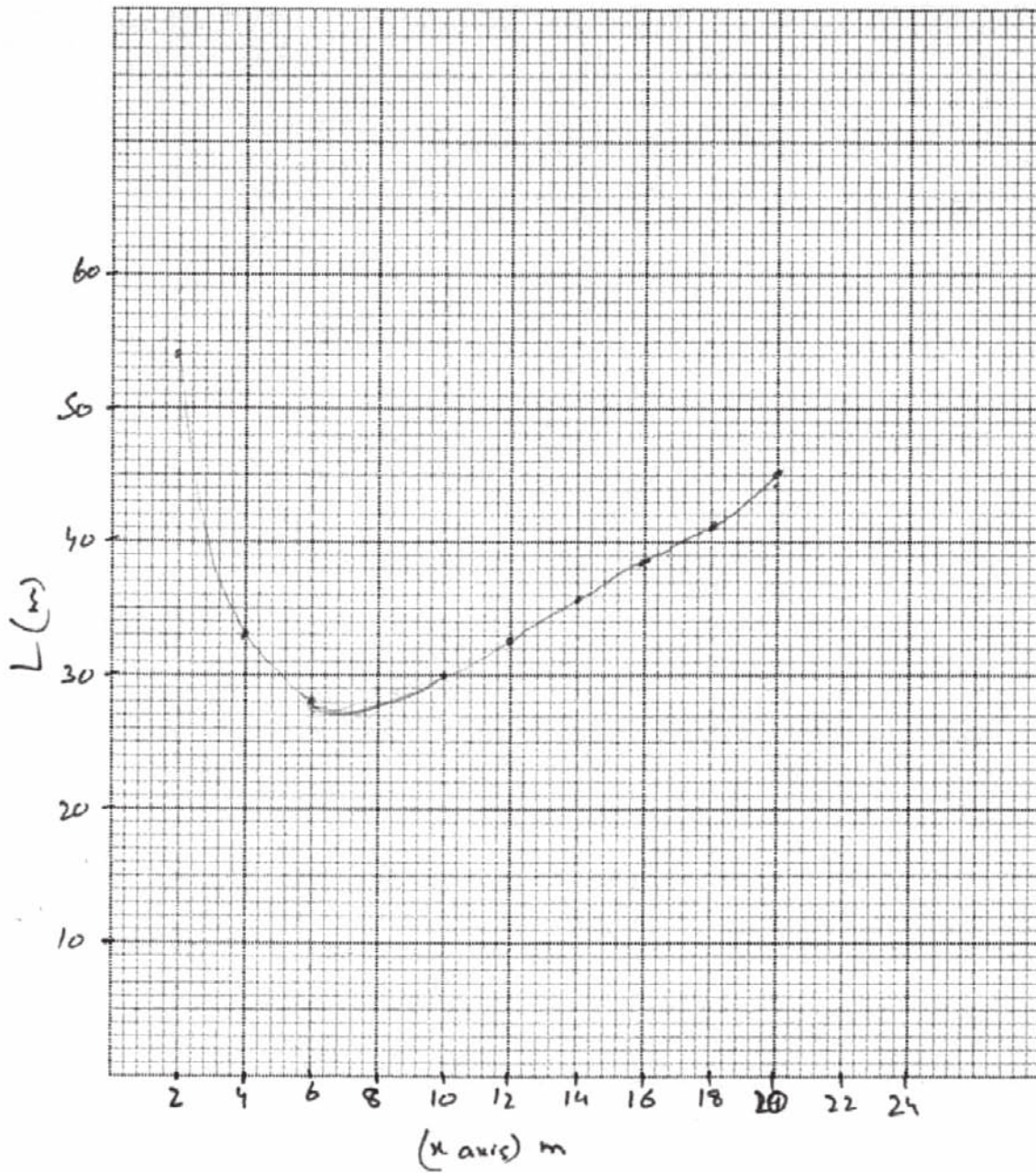

Examiner comment – grade E

- (a) An attempt is made to juggle the given expression but a basic error is made in the first line. No doubt if the question had suggested a first step, asking for an expression for the shorter side, there would have been much more success, but it had been expected that more candidates would have taken this step without the hint.

Mark awarded = 0 out of 2

- (b) The slight error in the value at $x = 18$ comes within the accepted range although candidates should be aware that all answers should be given correct to three significant figures.

Mark awarded = 2 out of 2

- (c) The candidate uses the correct scales and has the right ideas but mistakes in plotting the points at $x = 6$ and $x = 8$ has lost marks.

Mark awarded = 1 out of 3

- (d) It is difficult to know where these two values come from.

Mark awarded = 0 out of 2

- (e) (i) The candidate knows what is needed here but the earlier inaccuracies in plotting means that this value is outside the acceptable range.
(ii) A difficult part and the candidate has not recognised what the question is asking.

Mark awarded = 0 out of 2

- (f) Another difficult part which few candidates can tackle successfully.

Mark awarded = 0 out of 1

Total mark awarded = 3 out of 12

Question 11

Mark scheme

<p>11 (a) (i) $EC = BE$ or $AC = FE$ and $\angle AEC = \angle FBE$ or $\angle ECA = \angle BEF$ Two correct reasons for their choices</p> <p>Third statement, leading to correct congruence condition i.e. RHS, SAS, SSA</p> <p>(ii) BFD</p> <p>(iii) $\angle EBF = \angle DFB = 90^\circ$ Cointerior/interior/supplementary/allied angles [sum to 180] OR $\angle BEF = \angle EFD = 60^\circ$ Alternate angles [are equal]</p> <p>(iv) 120°</p> <p>(b) (i) 6.126 to 6.13</p> <p>(ii) 38.2 to 38.3</p>		<p>B1 B1</p> <p>B1</p> <p>1</p> <p>1 1dep</p> <p>OR 1 1dep</p> <p>1</p> <p>2</p> <p>3</p>	<p>Statements and reasons: $EC = BE$; radii $AC = FE$; diameters $\angle AEC = \angle FBE [= 90^\circ]$; angle in semicircle $\angle ECA = \angle BEF [= 60^\circ]$; equilateral triangle</p> <p>Both 90° could be marked on diagram</p> <p>Both 60° could be marked on diagram</p> <p>120° could be marked on diagram</p> <p>M1 for $\frac{1}{2} \times 4 \times 4 \times \sin 130$ Or $\frac{1}{2}PQ \times$ perpendicular height (numerical)</p> <p>M1 for $\frac{(360-130)}{360} \times \pi \times 4^2$ soi by 32.11 or $\frac{130}{360} \times \pi \times 4^2$ soi by 18.15 And M1 for ‘their major sector area’ + ‘their triangle area’ Or for ‘their circle area’ – ‘their minor sector area’ + ‘their triangle area’</p>
----------------------------------------------------------------------------------------------------------------------------------------------------------------------------------------------------------------------------------------------------------------------------------------------------------------------------------------------------------------------------------------------------------------------------------------------------------------------------------------------------------------------------------------------------------------------------------------------------------------------------------------------------------------------------------	--	---------------------------------------------------------------------------------------------------------------	---------------------------------------------------------------------------------------------------------------------------------------------------------------------------------------------------------------------------------------------------------------------------------------------------------------------------------------------------------------------------------------------------------------------------------------------------------------------------------------------------------------------------------------------------------------------------------------------------------------------------------------------------------------------------------------------------------------------------------------------------------------------------------------------------------------------------------------------------------------------------------------------------------------------------------------------

Example candidate response – grade A

- 11 (a) The diagram shows two circles with equal radii.
 A, E and C are points on the circle, centre B.
 B, E, D and F are points on the circle, centre C.
 ABCD is a straight line.

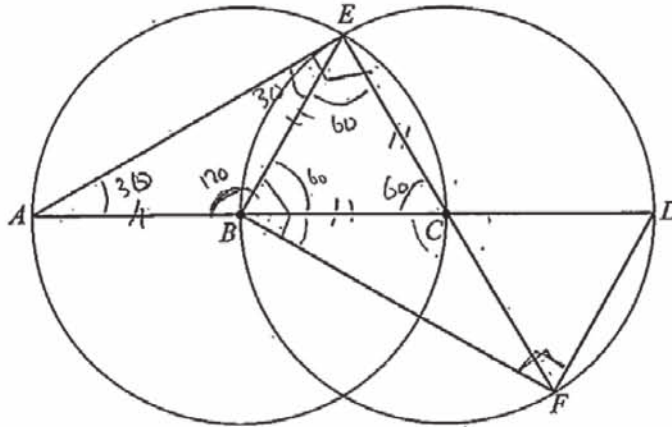

(i) Show that triangles AEC and FBE are congruent.

- $\angle AEC$ and $\angle FBF$ are 90° (\angle subtended by the diameter and touches the circumference are always equal to 90°)
 - ~~AC is the diameter of and FE are the diameter of a circle so we can say they both are equal~~
 - EC and BE are the radius of the circle so they would be equal
 - $\triangle AEC$ and $\triangle FBE$ are congruent by a property Right-angle, Hypotenuse and side. (RHS)
- [3]

(ii) State another triangle that is congruent to triangle AEC.

Answer Triangle BFD [1]

(iii) Explain why EB is parallel to DF.

Answer EB and DF are the chord and the radius of a circle are touching the corners of both the lines. [2]

(iv) Work out $\angle ABE$.

~~180 - 60 = 120~~
~~180 - 60 = 120~~
 $\triangle EBC$ are equilateral
 so they $\angle B$ is 60°
 $180 - 60 = 120$ (\angle as a straight line) Answer 120 [1]

- (b) P and Q are points on the circle centre O with radius 4 cm.
 $\hat{POQ} = 130^\circ$.

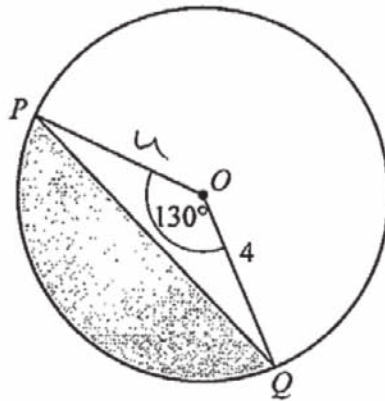

- (i) Calculate the area of triangle POQ .

$$\frac{1}{2} \times 4 \times 4 \times \sin 130$$

$$8 \times \sin 130$$

Answer 6.13 cm² [2]

- (ii) Calculate the area of the major segment, shown unshaded in the diagram.

$$\frac{230}{360} \times 3.142 \times 4^2$$

$$\frac{23}{36} \times 3.142 \times 16$$

$$\frac{23}{9} \times 3.142 \times 4$$

Answer 32.1 cm² [3]

Examiner comment – grade A

- (a) Parts (i) and (iii) proved to be difficult, with many candidates clearly not prepared for this type of geometrical question.
- (i) This candidate, however, produces an excellent answer to this part of the question. The slight slip in writing FBF instead of FBE was not penalised since the intention was clear. The solution is not presented in the traditional way but it is clear that the candidate understands exactly what the proof requires. The necessary equalities are stated, the reasons for these equalities stated and correct reason is then given for the congruence (RHS). This solution is one of a very small number that was given all three marks although a high proportion picked up one or two. Quite a good number of strong candidates lost the third mark when, after stating the same three equalities and reasons as this candidate the reason for congruence was given as SAS.
 - (ii) Most candidates were able to give this angle.
 - (iii) This, again, was particularly difficult and only the very strongest candidates gained both marks. This candidate's statement did not earn anything, but the two right angles BFD and EBF marked in the diagram did get one (perhaps fortunate) mark.
 - (iv) A clear method and reasoning gives the correct answer and gains the mark.

Mark awarded = 6 out of 7

- (b) (i) Most candidates at this level gained the two marks here, most of them using this $\frac{1}{2}absinC$ formula.
- (ii) This answer is allowed one mark for correctly finding the area of the major sector, but the candidate has confused 'sector' and 'segment' and ignored the statement 'unshaded in the diagram'. This was a common mistake.

Mark awarded = 3 out of 5

Total mark awarded = 9 out of 12

Example candidate response – grade C

- 11 (a) The diagram shows two circles with equal radii.
 A, E and C are points on the circle, centre B.
 B, E, D and F are points on the circle, centre C.
 ABCD is a straight line.

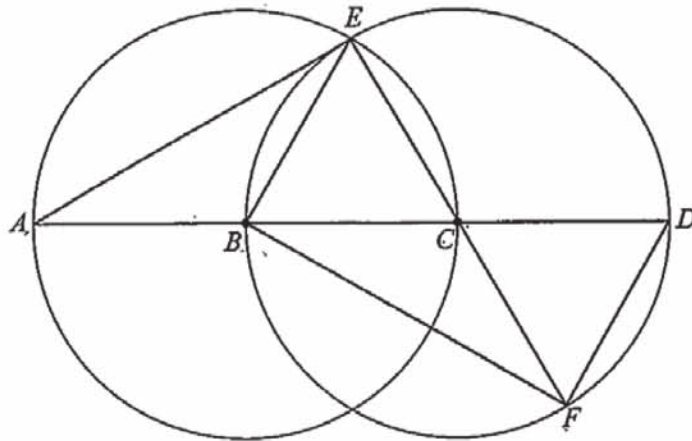

- (i) Show that triangles AEC and FBE are congruent.

AE is equal to FB, EC is equal to BE
 and AC is equal to FE which proves
 that these both triangles are congruent.
 $AE + EC + AC = FB + BE + FE$.

[3]

- (ii) State another triangle that is congruent to triangle AEC.

Answer Triangle ~~AEC~~ BDF [1]

- (iii) Explain why EB is parallel to DF.

Answer As they are making cyclic quadrilateral
 and they are opposite chords or they
 are making alternate angles. [2]

- (iv) Work out $\hat{A}BE$.

Answer 90° [1]

- (b) P and Q are points on the circle centre O with radius 4 cm,
 $\widehat{POQ} = 130^\circ$.

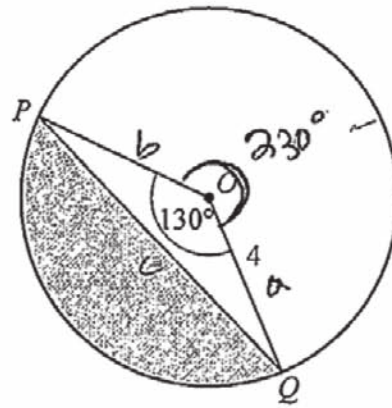

- (i) Calculate the area of triangle POQ .

$$\frac{1}{2} \times a \times b \times \sin C$$

$$\Rightarrow \frac{1}{2} \times 4 \times 4 \times \sin 130$$

$$\Rightarrow 2 \times 4 \times \sin 130$$

$$\Rightarrow 8 \times 0.766$$

$$\Rightarrow 6.128$$

Answer 6.128 cm² [2]

- (ii) Calculate the area of the major segment, shown **unshaded** in the diagram.

$$\frac{\theta}{360} \times \pi r^2$$

$$\Rightarrow \frac{230}{360} \times 3.142 \times (4)^2$$

$$\Rightarrow 0.639 \times 3.142 \times 16$$

$$\Rightarrow 32.123$$

Answer 32.123 cm² [3]

Examiner comment – grade C

- (a) (i) The candidate has listed the three sides in the triangles that are equal but has given no reasons at all. It might have been thought that two of the pairs were obvious but the equality of AE and BF would certainly need some justification. Many candidates did earn one mark by giving one pair of sides and the right angles and a second mark if the reasons were also given.
- (ii) The candidate had no difficulty with this part.
- (iii) The candidate perhaps had some idea of what was required when writing ‘they are making alternate angles’, but there is no indication of which angles or why, and the rest of the answer does not help.
- (iv) This wrong answer of 90 was fairly common but, with no working shown, it is hard to think it was anything other than a guess.

Mark awarded = 1 out of 7

- (b) (i) In this question the accuracy of the answer was not specified and there is no penalty for leaving the answer to 4 or more significant figures. The candidate thus has no problem here and gets both the marks. However, when candidates do correct to 3 significant figures, they must be careful to do so correctly. Candidates who went straight from $8 \sin 130$ to 6.12 lost the accuracy mark.
- (ii) One mark is earned for finding the area of the major sector but the question is not completed.

Mark awarded = 3 out of 5

Total mark awarded = 4 out of 12

Example candidate response – grade E

- 11/ (a) The diagram shows two circles with equal radii.
 A, E and C are points on the circle, centre B.
 B, E, D and F are points on the circle, centre C.
 ABCD is a straight line.

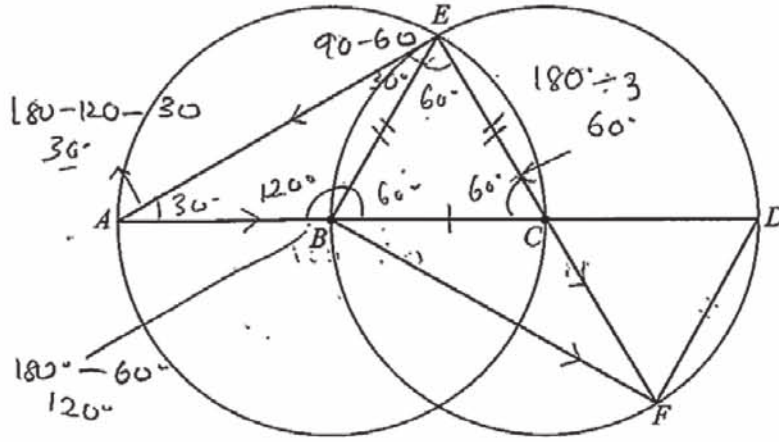

- (i) Show that triangles AEC and FBE are congruent.

[3]

- (ii) State another triangle that is congruent to triangle AEC.

Answer Triangle DFB [1]

- (iii) Explain why EB is parallel to DF.

Answer line of EB is congruent with the line of DF
 in the same direction [2]

- (iv) Work out \hat{ABE} .

$180^\circ - 60^\circ$

Answer 120° [1]

- (b) P and Q are points on the circle centre O with radius 4 cm.
 $\widehat{POQ} = 130^\circ$.

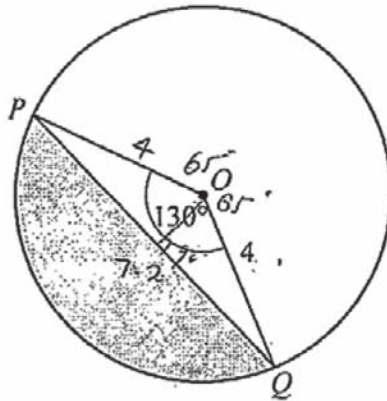

- (i) Calculate the area of triangle POQ .

$$\begin{aligned} & \frac{1}{2} \times b \times h \\ & \frac{1}{2} \times 4 \times 7.2 \\ & 14.4 \text{ cm}^2 \end{aligned}$$

$$\begin{aligned} \sin 65^\circ &= \frac{\text{opp}}{\text{hyp}} \\ \sin 65^\circ \times 4 &= \text{opp} \\ 3.6 \times 2 &= 7.2 \text{ cm} \end{aligned}$$

Answer 14.4 cm² [2]

- (ii) Calculate the area of the major segment, shown unshaded in the diagram.

$$\begin{aligned} & \pi r^2 h \\ & \pi \times 4^2 \times 7.2 \\ & 362 \text{ cm}^2 \end{aligned}$$

Answer 362 cm² [3]

Examiner comment – grade E

- (a) The diagram shows some good knowledge of angles but nothing about proof of congruence of parallelism. Two marks are earned in parts (ii) and (iv).

Mark awarded = 2 out of 7

- (b) (i) The candidate finds the length of PQ and then tries to use it in the formula $\frac{1}{2} \times \text{base} \times \text{height}$ but does not realise that a further calculation is necessary to find the height. In addition the candidate should be aware that approximating $4 \times \sin 65$ to 3.6 would probably have lost the accuracy mark, even with an accurate height.
 (ii) The candidate tries to use the formula for the volume of a cylinder to find the area of a segment.

Mark awarded = 0 out of 5

Total mark awarded = 2 out of 12

Cambridge International Examinations
1 Hills Road, Cambridge, CB1 2EU, United Kingdom
Tel: +44 (0)1223 553554 Fax: +44 (0)1223 553558
Email: info@cie.org.uk www.cie.org.uk

© Cambridge International Examinations October 2014 v1

